

WINTER
2024-25

GRANITEDESIGN

stone resource guide



how we came to be **GRANITEDESIGN**

[We are much more than just square footage!]

1998

[our humble beginnings]

The first project is created in the owner's residential garage in Ayer's Cliff, QC. Space is tight real quick!

1999

[the first shop]

Operations move Villeneuve Street in Stanstead, Qc in a small 5000SF building, with one employee and one saw.

2001

[Agenda Software]

Orders come in, to manage them efficiently, Agenda is launched on September 11, 2001.

2002

[a small detour]

The owners purchase a granite quarry in Magpie, QC. The rough northern climate brings that chapter of our history to a swift end, so that efforts can be brought back to the core business; fabrication.

2004

[we grow]

The Villeneuve street shop expands 4 times. The Silestone by Cosentino product, then exclusive to **GRANITEDESIGN**, is popular & contributes to our success.

2005

[a new factory]

Space is tight again. The company moves onto Industrielle Street, in a new 20 000SF facility, where 40 employees produce about 50 projects per week.

2013-14

[15 years]

The company marks this milestone with a new logo.

2016

[automation]

A Kuka robot and 2 dual head (waterjet and blade) Breton Saw lines are installed on an interchangeable table system; a line that still sets itself apart from the rest worldwide, and our Vermont Proximity Center opens in Derby Line, VT.

2018

[20 years]

4.1M is invested in expanding the fabrication floor, adding new equipment and office spaces. End 2018 early 2019, our Maine Proximity Center officially opens.

2019-20

[our DNA]

We redefine our values; TEAM, PRIDE and PERFORMANCE, that remain at the center of all our actions & decision process.

2023-...

[our talent]

We reach the 25-year milestone by inaugurating our Employer of Choice program, which puts focus on our passionate employees.

table of CONTENT

[to help you find what you need]

GENERAL INFORMATION

Being Ready for Install	72	How Countertops are made	5	Samples and natural stones	6
Being Ready for Template	72	Inventory Cycle at GRANITEDESIGN	4	Symbol Chart	4
Builder Program	28	Natural Stone Characteristics	7	The #1 enemy of stone countertops	71
Care & Maintenance - Silestone	27	Online Information	65	The GRANITEDESIGN Difference	2
Fabrication Process	5	Partner Connection	65	Variation Chart - Natural Stones	6
Frequently Asked Questions	69	PerfectF.I.T.™	3		
GRANITEDESIGN Service Exclusions	72	Roles in the process	70		

STONES

Bergen (Dekton)	30	Grey Expo (Silestone)	29	Rem (Dekton)	31
Black Galaxy (granite)	15	Grigio (Dekton)	40	Soapstone (soapstone)	10
Blue Pearl (granite)	9	Halcyon (Silestone)	29	Somnia (Dekton)	32
Blanco Maple (Silestone)	29	Kelya (Dekton)	37	Statuario (Silestone)	21
Calacatta Gold (Silestone)	19	Laurent (Dekton)	33	St-Henry (granite)	8
Corktown (Silestone)	22	Marina (Dekton)	35	Toscana Cream (Silestone)	16
Dakar (quartzite)	12	Miami Vena (Silestone)	29	Vigil (Dekton)	38
Desert Silver (Silestone)	18	Miami White (Silestone)	28	Viscount White (granite)	14
Domoos (Dekton)	36	Morpheus (Dekton)	41	White Macaubas (quartzite)	13
Ethereal Glow (Silestone)	17	Neural (Dekton)	34		
Ethereal Haze (Silestone)	23	Orinoco (granite)	11	Top Silestone Sellers	26
Ethereal Noctis (Silestone)	24	Pearl Jasmine (Silestone)	20	Top Dekton Sellers	42
Grafite (Dekton)	39	Poblenou (Silestone)	25		

SINKS

Kitchen - Custom-made	61	Anti-Stain Treatment	49
Kitchen - Integrity	62	Arcs & Bumpouts	53
Kitchen - Stainless Steel	62	Backsplashes	52
Vanity - Custom-made	61	Brackets & supports	55
Vanity - Porcelain	63	Chip Minimizer	49
		Countertop Overhang	53
		Custom Undermount Cut-out	51
		Drainboards	51
		Drain Kit (pop-up)	61, 63
		Edge Profile	46, 47

OPTIONS

Layout Viewer	56
Mineral Oil - Soapstone	10
Outdoor Kitchens	58
Radius Chart	54
Seam Smoother	50
Stone Care Kit	48
Surface covering	48
Surface Rip-Down	50
Undersurface polishing	57
Vein Flow	57
Waterfall Legs	55

WARRANTIES

Overview	67
Custom-made stone sinks - leaks	61
Seam & sink adhesive performance	50

TECHNICAL INFORMATION

Calculating a linear foot	64	Inside Radius	47
Calculating a square foot	64	Installing Full Height Cabinets	66
Calculating arcs & bumpouts	53	Lemon Test - for marbles	12
Calculating the number of slabs	64	Material Average Weight	55
Countertop overhang maximum	53	Material Comparison - Outdoors	58
Dekton - Cut-outs	45	Microfissure	7
Dekton - Edge profile colour	43	Pitting	7
Dekton - Edge profiles	31	Radius Chart	54
Dekton - Inside radius	45	Resistance levels per material	68
Dekton - Seams	43	Seams - Industry Standards	50
Dekton - Support & cabinets	44	Seams - Types and placement	67
Dekton - Variable pattern	44	Sinks - Factors to consider	60
Dekton - Waterfall legs	45	Sinks - Minimum Clearance	60
Etching	7	Stone Installation Standards	66
Finishes - Natural Stones	8	Surface hardness scale	65
		Tile Edge	52
		Ukiyo Texture	43
		Variance in Shine	7



each creation
IS UNIQUE

Dekton Arga | Design : Armoires Cordeau | Fabrication & Installation : Granit Design | Photo : Sarah Dagenais

INSPIRATION that fuels customers and designers

comes from so many sources [and that's a great thing!]. Whether it be design shows, social media, magazines, and more; customers have more information than ever to find the right teams to render their vision and make their dreams come true.

With over 150 000 projects fabricated in a quarter of a century, **GRANITEDESIGN** has seen its share of stunning concepts, created by renowned designers, with final results that are fit for a Magazine cover.

Yet, that sought-after cover page look is not achieved without a few hurdles, and requires, among many things, two very essential elements.

...

Patience and empathy. Patience to take the time required and coordinate each step with careful consideration, and accepting the fact that it can take more than one try to achieve the desired outcome. Empathy to be able to imagine what it is like for the other parties involved, to acknowledge their challenges, their reality, so that mutually beneficial solutions can be found throughout the process, keeping things moving forward towards the ultimate goal; **the customer's entire satisfaction.**

By working together, we can continue to reach our **mission** ; of **transforming each made-to-measure project into your dream masterpiece.**



THE DIFFERENCE

[with GRANITEDESIGN]



A POPULAR SELECTION

With a selection of reputable brands such as Cosentino (makers of Silestone and Dekton), and beautiful natural stones (granite, quartzite, soapstone, etc.), we ensure that you have access to the most popular stones to fulfill your creative design needs !



PEACE OF MIND

For over 25 years, we have been fabricating each made-to-measure project, prioritizing customer's peace of mind by :

- ✓ Using trusted partner distributors;
- ✓ Ensuring training for all our employees
- ✓ Performing background checks on all technicians



PRECISION LIKE A HAWK

Whether it be our order management system, our laser templating, our automated inspection & treatment line, our robots, saws, CNC's, we invest to make sure our production capacity and quality are at the top of our field.

And of course, our strongest advantage; our artisans who have your project to  at every step of the process.



THE CREDIBILITY OF PROFESSIONAL ASSOCIATIONS

To remain ahead of the pack, we educate ourselves, maintain our knowledge base, by being active members of the following associations :



GRANITEDESIGNUSA.COM
1-866-761-8700

VERMONT | NEW HAMPSHIRE | MAINE

Stanstead
Fabrication Facility

Vermont
Proximity Centre
American Division

Maine
Proximity Centre
American Division

Dartmouth
Proximity Centre



THE ONLY FABRICATOR TO OFFER THE Perfect F.I.T.™

by GRANITEDESIGNUSA



[What's that?]

By working in complete synergy with our trusted distributors, **GRANITEDESIGN** offers an exclusive wall templating process that allows us to fabricate countertops while our distributors create cabinets, enabling us to install countertops 1 business day after cabinets are fully installed.

COUNTERTOP INSTALLATION
1 BUSINESS DAY
after cabinets are fully installed

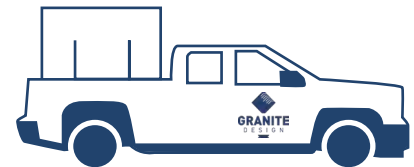

The advantages of our PerfectF.I.T.™ for your customer



SAVE
TIME



REGAIN THE COMFORT
OF YOUR HOME FAST



QUALITY CONTROL
GUARANTEED



HIGH-END
EXCLUSIVE PROCESS

HOW DOES IT WORK?

It is **NOT** just fabricating basing ourselves on your plans. Our teams work with a wall laser templating technique and only offers this service to experienced cabinet makers who have trusted processes and teams in place. There are a few particularities to ensure a site can qualify, including :

- ⊙ walls must have gyproc and plaster ;
- ⊙ walls must be clean and not damaged ;
- ⊙ the space must be free of all objects during the template.

**Read more on
the subject here!**





what it means ? 15 days of inventory

[It goes by fast]

With the volume required to service all our distributors, **GRANITEDESIGN** orders and receives material for your projects on average **13 to 15 business days** prior to the anticipated fabrication date, which is on average **10 business days** prior to installation.

The inventory you see here will empty itself every







15 DAYS

and will be replenished again !

SYMBOL CHARTS









FINISHES

Finishes that are darker are the ones by default. If there are finishes that are in gray, they are available in option.

-  Polished
-  Honed
-  Antique/Textured
-  Suede
-  Velvet
-  UltraMatte







RESISTANCE

Materials are resistant to, but are NEVER bullet-proof.

-  Stains
-  Scratches
-  Heat
-  Temperature change
-  Acid
-  Abrasion
-  Heat (high)
-  Scratches (high)
-  UV Rays

CHARACTERISTICS

Stones are subject to certain phenomenons, that are not defects, but are part of what makes the stone unique.

-  Microfissures
-  Handle with care
-  Etching
-  Pitting
-  Variance in Shine
-  Requires frequent cleaning
-  Possible break in motif at seam/junction

GDGuard™ TREATMENT



Stones that have this shield will benefit from receiving our exclusive long-lasting anti-stain treatment that is accompanied by a **15-yr warranty on food & beverage stains** (applicable to granites & quartzites only).

Keep an eye out for this symbol when to offer the option when it is most recommended!

have you ever wondered how countertops are made?

By looking at a countertop, we could think that it is quite simple. Pieces are measured, fabricated, and installed [easy, right?]. Wrong! There is no identical project, no identical slab, so it is much more complex than what meets the eye!

Mother Nature is the creator

of all granite, marble, quartzite, soapstone [basically, all natural stones]. She creates each stone unique, and perfectly imperfect! Before reaching our fabrication facility, a stone is :



QUARRIED
from the ground using explosives or diamond saws.

CUT
into very large blocks.

CUT (again)
into slabs, which can take up to 3 days.

POLISHED
to the finish available on the market.

Check out how this is done with this video!



Humans are creators

of mineral, compact (like porcelain) and ultra-compact surfaces (like Dekton). A bit like preparing a cake, high-quality ingredients such as minerals, pigments and bonding agents when needed are combined, moulded, heated and cooled, resulting in a wide variety of styles and finishes.

No slab is perfectly identical to the other, but they are quite consistent.

Check Out How Dekton is made!



Next, the GRANITEDESIGN experts

put their passion for stone to your service. Your project will cross many steps (and many sets of hands) before being installed:



PROJECT OPENING
[the more info we have, the better!]



TEMPLATE
[details are finalized]



PURCHASE & INSPECTION
[material arrives!]



LAYOUT
[optional]



PRODUCTION PLANNING
[the point of no return!]



CUTTING
[almost done!]



PACKAGING
[each route is packaged in order]



INSTALL
[be ready for our technicians!]

Our videos

to discover the main steps of our fabrication process.

INSPECTION
[see how stone arrives at our facility]



INITIAL CUTTING
[check out our robots!]



MACHINING
[where each project takes shape]



FINAL CARE
[the last steps of the fabrication process]



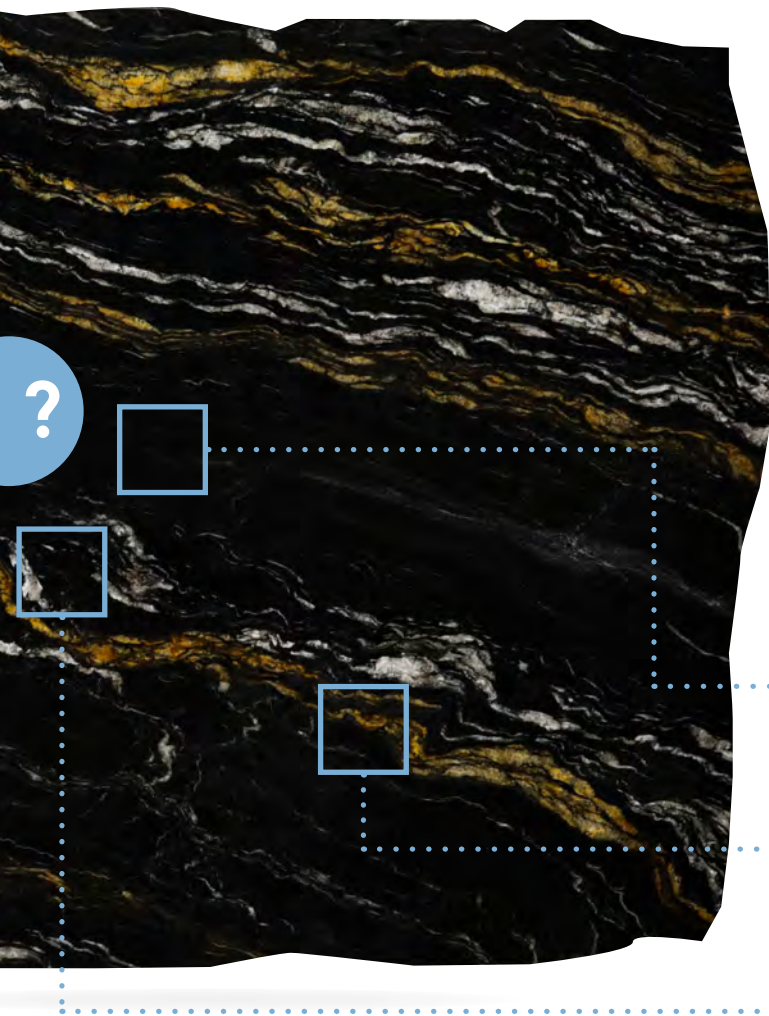

understanding natural variation

Each natural stone is **UNIQUE**. This means that each slab will have its own veining, its own color/mineral composition, and no slab will be identical to the next. If your customer is not comfortable with this, maybe consider low-variation natural stones, or engineered stones (like mineral or ultra-compact surfaces).



SAMPLES

Each sample is only a small portion of a slab. The more a stone has a higher degree of variation, the more the sample may be different from one to another.



Slab photo : Orinoco granite

understanding the variation chart

SYMBOL	LAYOUT SERVICE	COMMENTS
1 Low variation	Not offered	Type of stone ideal for large-scale projects.
2 Medium variation	Available	Will have a certain level of variation, but sufficiently consistent to find enough material for large-scale projects.
3 High variation	Strongly recommended	High variation from one slab to another. Will be difficult to find similar slabs after a few months, so plan ALL surfaces at the same time (countertop, backsplash, threshold, windowsill, etc.).
 Pitting	N/A	The stone will be subject to small craters. They do not affect the durability or protective performances of the GDGuard™ treatment.
 Microfissure	N/A	May have meshing on the back. Rip down and more complex edge profiles may not be recommended.
 4 Handle with care	Strongly recommended	Will have meshing on the back, and may have fiberglass coating around the slab. The stone is considered exotic (more fragile). Rip down, complex edge profiles and other fabrication limitations may apply depending on the project.

The characteristics of Natural Stones

Taj Mahal Quartzite antique finish | Template & Installation : Granit Design



ETCHING

Is encountered with marbles when the surface is in contact with acid. Many foods, beverages or household products can be the source of this phenomenon (lemon/citrus juice, sauces, coffee, wine, bleach, etc.). Will create a watermark effect, slightly rough to the touch. A repolishing can be done to correct the situation, or choosing a honed finish will ensure the effect is less visible over time.



PITTING

Is the result of small superficial craters left behind when softer minerals (ex.: mica) detach from the slab during the initial polishing process, or even over time with normal wear & tear. The craters will create a slight texture, like an orange peel. The quality and resistance levels of the stone are not impacted by this.



MICROFISSURE

More present in exotic natural stones, they are old fractures that allowed water to penetrate and create the beautiful colors that we admire today. Over millions of years, these fractures have welded back together under the extreme pressure and heat in the earth.



VARIANCE IN LEVEL OF SHINE

More present in exotic natural stones that have different mineral combinations of various levels of hardness. Softer minerals (like mica) will not shine as much after the polishing process, which will create duller spots. It's like trying to polish an orange..! Even though apples and oranges are both fruits, the apple (denser) will shine easily. The orange (softer) will not, no matter how much you rub it!

the latest trends

Natural stones are IN!



GRANITEDESIGN is proud of working with world leaders such as Cosentino, to bring you the most stunning natural stones from all across the globe. Depending on your program, the availability of these colors may vary.



ST-HENRY (granite) | Canada | Slab ≈ 125 x 72

The St-Henry is a beautiful granite quarried in Canadian soil. With a rich and mysterious blend of ebony, charcoal and hints of blue, with a mineral structure that is subtle yet complex. Depending on the chosen finish, the stone's texture will vary.

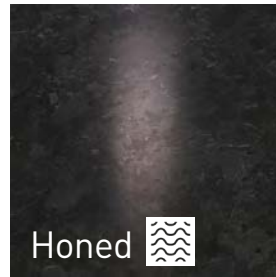
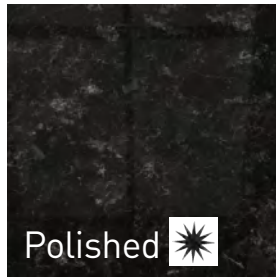

the importance of finish



With dark granites, **oily residues will be more visible on honed and polished finishes.** The antique finish will create an interesting texture and will dissimulate these residues better.

Natural Characteristics

Variation

Finishes

Resistance

Thickness

Applications



Layout not recommended



1 1/4"



Admire this Stone!
Scan the QR Code!



Encourage Local Stones Quarried in Our Ground

Buy local stones that are quarried by companies who put forward ecofriendly practices and have our worker's health & safety at  .

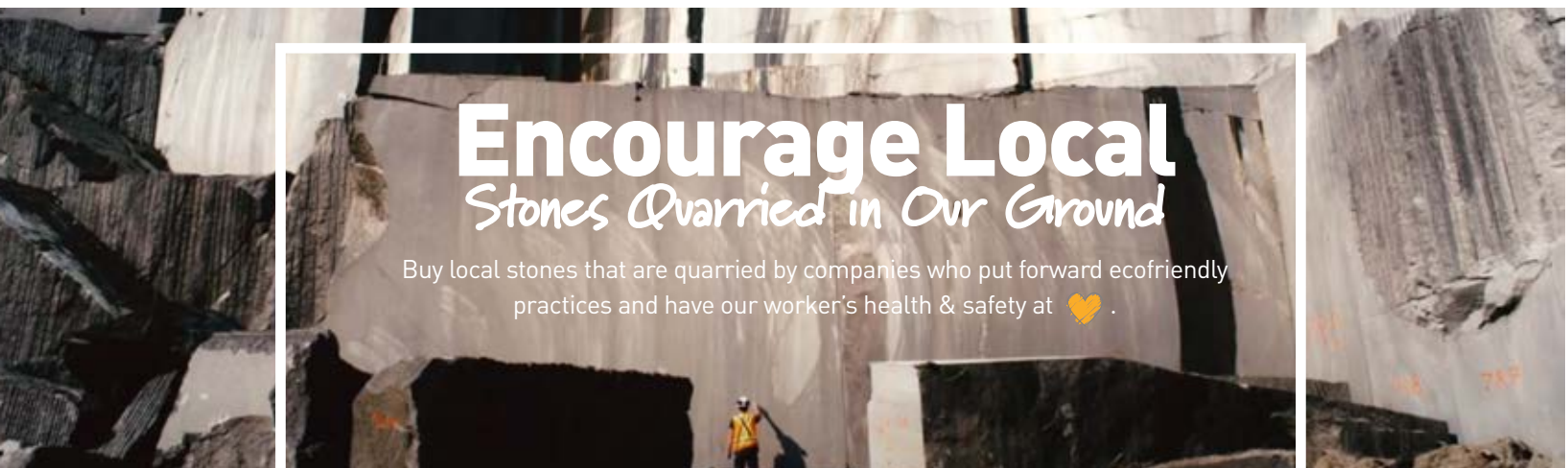

beautiful Natural Stones

are as easy to care for

as any other engineered surface if you choose our exclusive long-lasting anti-stain treatment backed by a 15-yr warranty against food & beverage stains! (valid on granite & quartzite)

BLUE PEARL (granite) | Norway | Slab ≈ 118 x 65

The Blue Pearl granite is a beautiful stone quarried in Norway. A tribute to the scandinavian climate, it features cool shades of blue, grey and ebony, with hints of white and mica that adds a tridimensional effect. All depending on the level at which this stone is quarried in the earth, the coloration will vary, but the mineral structure is fairly constant.



Beautiful,

these stones are unique focal points. When paired with rich tones, they create elegant designs that do not go unnoticed.

Natural Characteristics



Variation



Layout option available

Finishes



Resistance



Thickness

1 1/4"

Applications

interior

exterior



Champagne

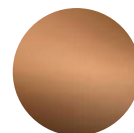

Bronze



Raven





SOAPSTONE | Brazil | Slab ≈ 116 x 68

Soapstone is a fascinating material used by the Brazilian people for centuries as cooktops. This stone is non-porous, therefore naturally antibacterial and stain resistant. It is also the natural stone with the highest resistance to heat. Its mineral composition makes it more prone to scratches. It can be oiled to enhance the veins or left in its natural state for a more rustic look. The coloration will vary from steel to dark grey depending on the lots.

Natural Characteristics



Variation

4

Layout strongly recommended

Finishes



Resistance



Thickness

1 1/4"

Applications

interior

exterior



you want the wet look?

Think of offering our mineral oil :

- ☑ Increases the stone color's depth;
- ☑ Increases the vein contrast ;
- ☑ Dissimulates fingermarks & oily residues better;
- ☑ Easily applied using a rag, as often as desired;
- ☑ Is odourless, colorless, and 100% food safe.



ORINOCO (granite) | Brazil | Slab ≈ 115 x 68

This unique stone features an intense blend of dynamic veins in various shades of white, gold and copper that crisscross a rich ebony background, creating a bold statement piece. Meshed to make it safe to handle, this stone may bring upon certain limitations in fabrication, but a carefully planned project will create an elegant and timeless design.

Natural Characteristics



Variation

4

Layout strongly recommended

Finishes



Resistance



Thickness

1 1/4"

Applications

interior

exterior

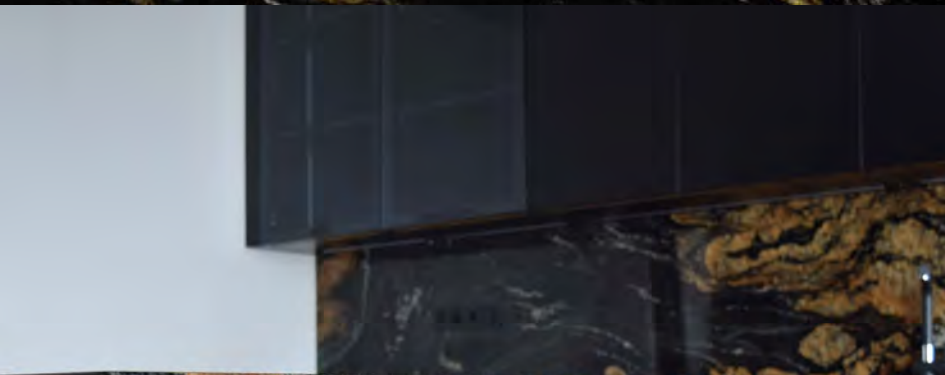

Beautiful,

these stones are unique focal points. When paired with rich tones, they create elegant designs that do not go unnoticed.



Stainless

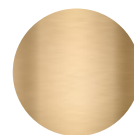

Brass



Raven





DAKAR (quartzite) | Brazil | Slab ≈ 116 x 68

This natural quartzite showcases a pale silver background with delicate veins that crisscross the slab in various shades of grey. It also features warmer subtle warmer tones of cream and beige, adding depth to this stunning stone.

Meshed to make it safe to handle, this stone may bring upon certain limitations in fabrication, but a carefully planned project will create an elegant and timeless design. Unlike marbles, quartzite will not react to acids and will therefore not be prone to etching.

Natural Characteristics



Variation



Layout strongly recommended

Finishes



Resistance



Thickness

1 1/4"

Applications

interior

exterior



dare to try
the lemon test

Take two lemon wedges. Place one on a Taj Mahal sample, and one on a marble of your choice (ex.: Bianco Carrara). Wait 5 to 10 minutes. Remove the lemon wedges and dry the samples completely. Observe the marble under different angles. What do you see? Can you see this on the Taj Mahal?

[that is what etching is!]



WHITE MACAUBAS (quartzite) | Brazil | Slab ≈ 115 x 68

This natural quartzite features a relatively linear vein in shades of grey, mossy green and moka, on a soft grey background. Meshed to make it safe to handle, this stone may bring upon certain limitations in fabrication, but a carefully planned project will create an elegant and timeless design. Unlike marbles, quartzite will not react to acids and will not be prone to etching. However this particular stone is prone to darkening on the edges over time.

Natural Characteristics



Variation



Layout strongly recommended

Finishes



Resistance



Thickness

1 1/4"

Applications

interior

exterior



Beautiful,

these stones are unique by their mineral composition. Paired with earthy tones, they create an elegant and timeless look.



Stainless

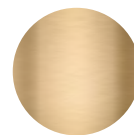

Brass



Raven





VISCOUNT WHITE (granite) | India | Slab ≈ 116 x 68

This granite quarried in India features a dynamic swirl of various shades of grey and ebony on an eggshell background. Its neutral tones make it a great stone for several wood types and cabinet styles. This granite can also be known as Silver Cloud.

Natural Characteristics



Variation

3

Layout strongly recommended

Finishes



Resistance



Thickness

1 1/4"

Applications

interior

exterior

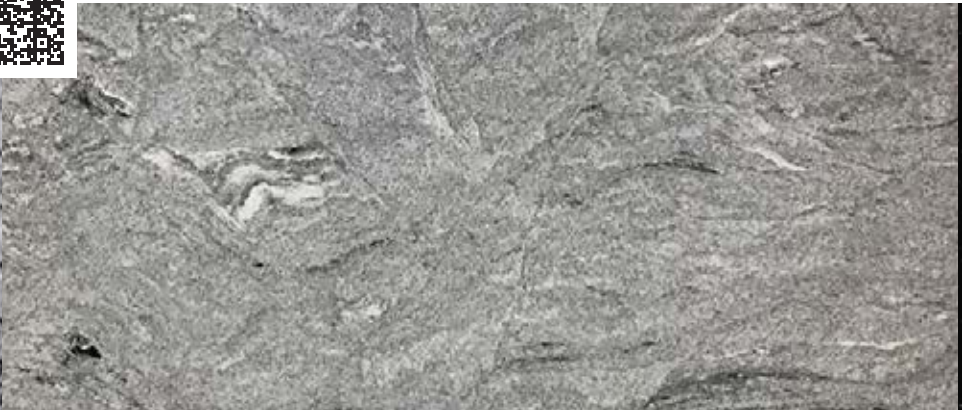

The marble of granite

The Viscount White has acquired over time a reputation of featuring fluid veins that remind people of marbles, yet with the carefree characteristics that make granite a popular choice.

It will never be comparable to Italian marbles, but this elegant stone remains nonetheless a must see!



BLACK GALAXY (granite) | India | Slab ≈ 120 x 70

This granite is quarried in India, in the region of Andhra Pradesh. With a fairly consistent mineral structure and tones that blend blacks, greys and chocolate browns with stunning gold flecks. Meshed to make it safe to handle and more prone to pitting and microfissures, this stone may bring upon certain limitations in fabrication, but a carefully planned project will create an elegant and timeless design.

Natural Characteristics



Variation

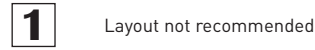

Finishes



Resistance



Thickness

1 1/4"

Applications



Beautiful,

these stones are timeless classics. Paired with warm surroundings, they will bring elegance to their surrounding.



Stainless



Brass



Raven



the latest trends

Mineral Surfaces remain a must see









GRANITEDESIGN is proud of working with Cosentino, industry leader, to shape your creations in high quality mineral surfaces that are fabricated with ecofriendly practices and include ingredients that put worker's health & safety first. Depending on your program, the availability of these colours may vary.

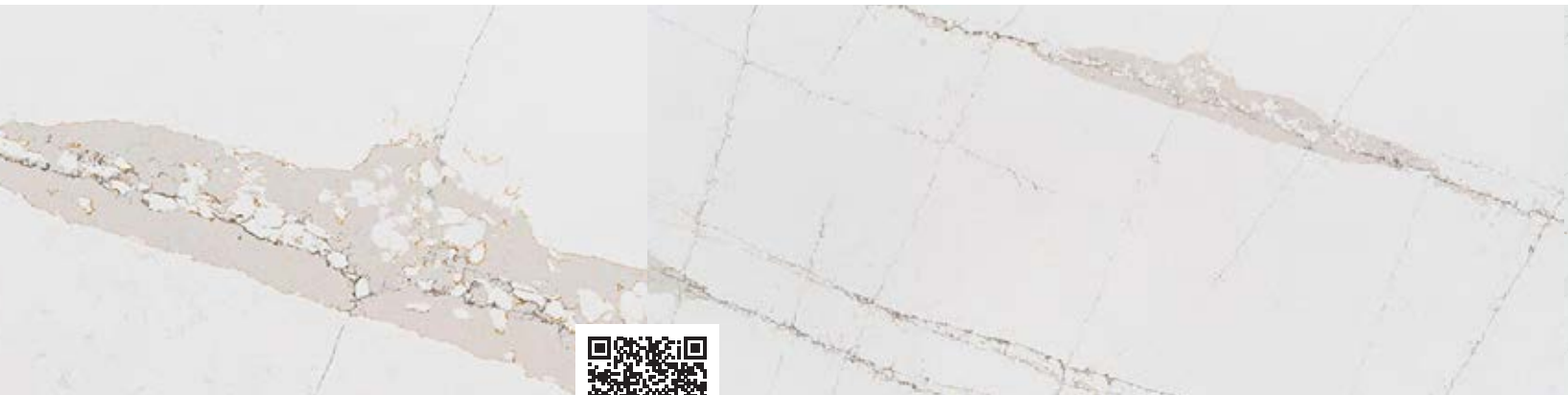

TOSCANA CREAM ( mineral surface) | Spain | Slab : 126 x 62

The Toscana Cream mineral surface offers a warm cream background with sophisticated veins in various shades of caramel, beige and taupe. Fabricated with Cosentino's innovative HybriQ technology, this process utilizes a new high-performance blend of quality ingredients for a more natural look, improved durability, and a production process entirely powered by renewable sources and recycled water.



Variation	3	Layout strongly recommended
Finishes		
Resistance	  	
Thickness	1 1/4"	
Applications	interior	exterior
Particularity		Always use a trivet to avoid thermal shocks & discoloration.

ENGINEERED STONE

Mineral surfaces
are an elegant and timeless material

that resists food & beverage stains, and offers good resistance levels to scratches [still, we recommend the use of cutting boards!]. More sensitive to heat, the use of trivets is strongly encouraged to avoid thermal shocks & discoloration.

ETHEREAL GLOW ( mineral surface) | Spain | Slab : 126 x 62

The Ethereal Glow showcases fine grey and golden veins that crisscross an off-white and cream background. Fabricated using Cosentino's HybriQ+ innovative technology, this process utilizes a new high-performance blend of quality ingredients for a more natural look and improved durability, and a production process entirely powered by renewable energy sources, recycled water, and uses up to 20% of recycled materials.



Variation

3

Layout strongly recommended

Finishes



Resistance



Thickness

1 1/4"

Applications

interior

exterior

Particularity



Always use a trivet to avoid thermal shocks & discoloration.











DESERT SILVER ( mineral surface) | Spain | Slab : 126 x 62

The Desert Silver mineral surface features a soft grey background with subtle eggshell veins, for a clean sophisticated look. Fabricated with Cosentino's innovative HybriQ technology, this process utilizes a new high-performance blend of quality ingredients for a more natural look, improved durability, and a production process entirely powered by renewable sources and recycled water.



- Variation** 3 Layout strongly recommended
- Finishes**  
- Resistance**   
- Thickness** 1 1/4"
- Applications** interior exterior
- Particularity**  Always use a trivet to avoid thermal shocks & discoloration.





CALACATTA GOLD ( mineral surface)
Spain | Slab : 126 x 62

The Calacatta Gold mineral surface is inspired by the most popular marbles, with a warm white background, soft grey veins and hints of gold. Fabricated with Cosentino's innovative HybriQ technology, this process utilizes a new high-performance blend of quality ingredients for a more natural look, improved durability, and a production process entirely powered by renewable sources and recycled water.

Variation

3

Layout strongly recommended

Finishes



Resistance



Thickness

1 1/4"

Applications

interior

exterior

Particularity



Always use a trivet to avoid thermal shocks & discoloration.



Beautiful,

these stones are crowd favourites. Paired with modern color schemes, they create a versatile and timeless design.



Stainless



Brass



Raven









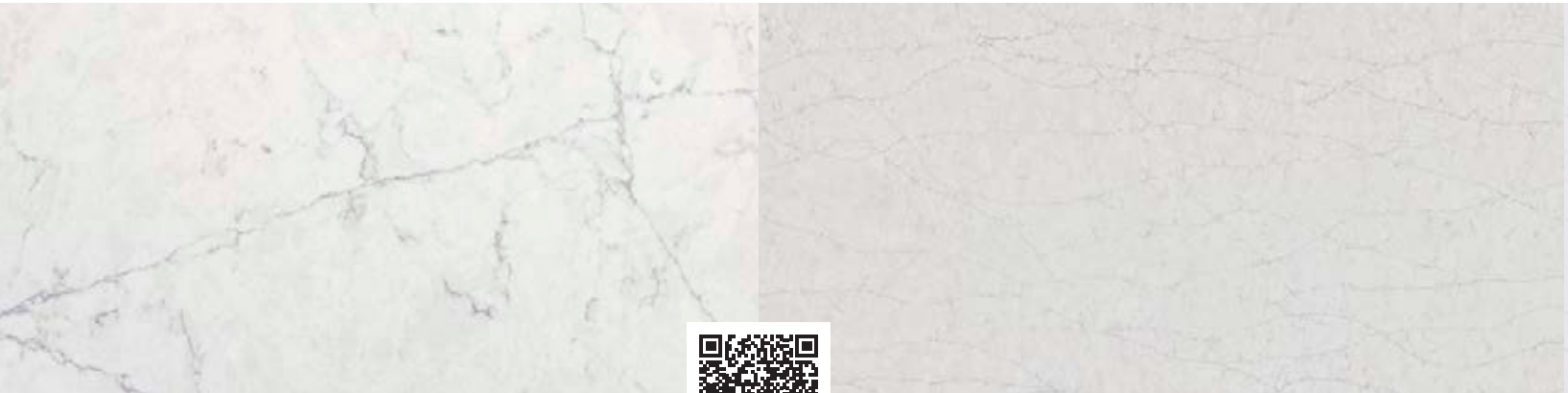



PEARL JASMINE ( mineral surface) | Spain | Slab : 126 x 62

The Pearl Jasmine mineral surface combines the classical elegance of traditional limestone with a touch of modern with delicate yet contrasting veins that run across the slab in a subtle crackle pattern, blending authenticity and sophistication. Fabricated with Cosentino's innovative HybriQ technology, this process utilizes a new high-performance blend of quality ingredients for a more natural look, improved durability, and a production process entirely powered by renewable sources and recycled water.



Variation	3	Layout strongly recommended
Finishes	 	
Resistance	  	
Thickness	1 1/4"	
Applications	interior 	exterior 
Particularity		Always use a trivet to avoid thermal shocks & discoloration.





STATUARIO ( mineral surface)
Spain | Slab : 126 x 62

The Statuario mineral surface is inspired by popular marbles, with a warm white background and vapory pale grey veins. Fabricated with Cosentino's innovative HybriQ technology, this process utilizes a new high-performance blend of quality ingredients for a more natural look, improved durability, and a production process entirely powered by renewable sources and recycled water.

Variation

3 Layout strongly recommended

Finishes



Resistance



Thickness

1 1/4"

Applications

interior **exterior**

Particularity



Always use a trivet to avoid thermal shocks & discoloration.

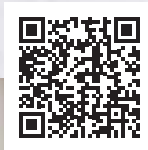

Beautiful,

these stones are crowd favourites. Paired with modern color schemes, they create a versatile and timeless design.



Stainless



Laiton



Noir Jais





CORKTOWN ( mineral surface) | Spain | Slab : 126 x 62

The Corktown mineral surface with a suede finish combines rich tones of brown, grey, mossy green and ebony, that blend together in a subtle yet complex pattern. Fabricated using Cosentino's HybriQ+ innovative technology, this process utilizes a new high-performance blend of quality ingredients for a more natural look and improved durability, and a production process entirely powered by renewable energy sources, recycled water, and uses up to 20% of recycled materials.



Variation

2

Layout option available

Finishes



Resistance



Thickness

1 1/4"

Applications

interior

exterior

Particularity



Always use a trivet to avoid thermal shocks & discoloration.





ETHEREAL HAZE ( mineral surface)
Spain | Slab : 126 x 62

The Ethereal Haze is a bold stone with a neutral white background and contrasting veins in various shades of grey. Fabricated using Cosentino's HybriQ+ innovative technology, this process utilizes a new high-performance blend of quality ingredients for a more natural look and improved durability, and a production process entirely powered by renewable energy sources, recycled water, and uses up to 20% of recycled materials.

Variation

3 Layout strongly recommended

Finishes



Resistance



Thickness

1 1/4"

Applications

interior **exterior**

Particularity



Always use a trivet to avoid thermal shocks & discoloration.



Beautiful,

These stones have timeless designs. Paired with rich tones, they will create an elegant design.



Stainless

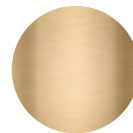

Brass



Raven





ETHEREAL NOCTIS ( mineral surface) | Spain | Slab : 126 x 62

The Ethereal Noctis mineral surface features delicate veins in shades of black and steel grey, on a neutral white background. The veins are more delicate than the Ethereal Haze. Fabricated using Cosentino's HybriQ+ innovative technology, this process utilizes a new high-performance blend of quality ingredients for a more natural look and improved durability, and a production process entirely powered by renewable energy sources, recycled water, and uses up to 20% of recycled materials.



Variation

3

Layout strongly recommended

Finishes



Resistance



Thickness

1 1/4"

Applications

interior

exterior

Particularity



Always use a trivet to avoid thermal shocks & discoloration.





POBLENOU ( mineral surface)
Spain | Slab : 126 x 62

The Poblenu mineral surface with a suede finish features a medium grey background with subtle cloudlike patterns in shades of pale grey and eggshell. Fabricated using Cosentino's HybriQ+ innovative technology, this process utilizes a new high-performance blend of quality ingredients for a more natural look and improved durability, and a production process entirely powered by renewable energy sources, recycled water, and uses up to 20% of recycled materials.

Variation

2

Layout option available

Finishes



Resistance



Thickness

1 1/4"

Applications

interior

exterior

Particularity



Always use a trivet to avoid thermal shocks & discoloration.



Beautiful,

These stones have timeless designs. Paired with rich tones, they will create an elegant design.



Stainless



Brass



Raven



Top Selling Mineral Surfaces by silestone®

Designed by COSENTINO



BIANCO CALAC. ✱



BLANCO MAPLE ✱



CORKTOWN ■



DESERT SILVER ✱



ET. CALACATTA GOLD ✱



ET. STATUARIO ✱



ETHEREAL GLOW ✱



ETHEREAL HAZE ✱



ETHEREAL INDIGO ✱



ETHEREAL NOCTIS ✱

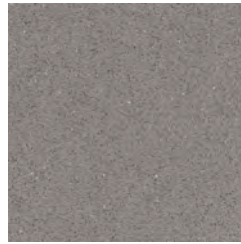

GREY EXPO ✱

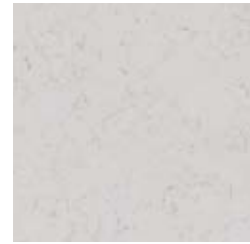

HALCYON ✱



MARENGO ✱



MIAMI VENA ✱



MIAMI WHITE ✱



PEARL JASMINE ✱



PIETRA ✱



POBLENOU ■

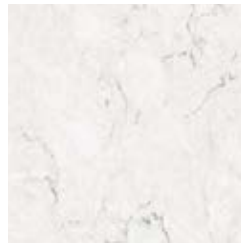

SNOWY IBIZA ✱



STELLAR SNOW ✱



TOSCANA CREAM ✱



WHITE ARABESQUE ✱

SLAB DIMENSIONS : Regular : 119 x 53 Jumbo : 126 x 62

FINISH BY DEFAULT Polished ✱ Suede ■

It is possible that certain colors be offered in Suede finish, but these are special orders. We recommend validating finish availability with our team.

WHEN SHOULD THE VEIN FLOW BE OFFERED?

When additional attention must be given to seams or junctions to improve vein fluidity. Ex.: a project with an oversized island and waterfall legs.

a few tips for these oops moments



DAILY

No matter which material you choose, maintenance is fairly easy. We also recommend the use of trivets to avoid thermal shock in relation to prolonged exposure to heat (ex.: under a slow cooker).

A FEW TRICKS for your mineral surface countertops!

Because no stone is bullet-proof, here are some quick tips to try !



ORGANIC SOURCES

[food coloring, spices, wine, mustard, coffee, etc.]

Spray the surface with Original Windex. Let it sit 5 minutes without it drying (spray as needed). Rinse, dry with clean microfibre cloth.



METALLIC SOURCES

[metal buckles, pots & pans, etc.]

Cover the area with a paper towel, exceeding the zone by 1 inch. Pour a bit of CLR on the paper towel. Cover with plastic wrap without sealing the edge. Let it sit 2 hours. Remove and scrub the area with a cloth dampened with CLR. Rinse, dry completely. Repeat as needed.



LIMESTONE

[creates a watermark residue often rough to the touch]

Remove the residue with a new scraper blade. Pour a bit of CLR on the area (protect walls, faucets, etc.). Let it sit 2 hours. Rinse thoroughly and dry completely. Repeat as needed.



OILY RESIDUES

[residues that will make a stone appear darker in affected areas]

Apply a coat of Comet Cream with bleach **WITHOUT SCRUBBING** and let it sit up to 20 minutes by keeping the area damp (spray with water or place wet towel on top). Gently wipe with clean wet sponge. Repeat as needed, then clean with daily method.



AVOID

- Metal scrubbing pads
- Degreasing agents
- Chlorine-based products
- Products with hydrofluoric acid
- Oven Cleaners
- Nail polish remover
- Any other product with pH levels superior to 10

timeless, durable, unbeatable Perfect for builders

Condo | Multi-unit | Commercial | Institutional

GRANITEDESIGN is proud of working with Cosentino, world leaders in their field, to ensure a constant supply of these stones at a competitive price, allowing construction industry professionals the possibility to offer customers a high quality, ecofriendly surface. Depending on your program, the availability of these colours may vary.



SELECTION
that offers quality materials with very little variation between lots



SUPPLY
in sufficient quantity, perfect for large-scale projects



PROFIT MARGINS
interesting for all



VALUE ENGINEERING
by our team to optimize and offer upgrades that will save you time & effort









SCHEDULED DELIVERIES
to adapt ourselves to the rhythm of a job site

All these mineral surfaces are fabricated with Cosentino's HybriQ innovative process, which utilizes a new high-performance blend of quality ingredients for a more natural look, improved durability, and a production process entirely powered by renewable sources and recycled water.

MIAMI WHITE (mineral surface) | Spain | Slab : 126 x 62

The Miami White offers a neutral white with a fine granulated texture in various shades of pale grey and translucent crystals.

Variation		Layout not recommended
Finishes		
Resistance	  	
Thickness	1 1/4" 3/4"	
Applications	interior exterior	
Particularity		Always use a trivet to avoid thermal shocks & discoloration.





HALCYON ( mineral surface) | Spain | Slab : 126 x 62

The Halcyon offers a warm white background with a subtle and elegant movement in various shades of pale grey and hints of gold.

Variation 1 Layout not recommended

Finishes 

Resistance   

Thickness 1 1/4" 3/4"

Applications interior exterior

Particularity  Always use a trivet to avoid thermal shocks & discoloration.

MIAMI VENA ( mineral surface) | Spain | Slab : 126 x 62

The Miami Vena offers a neutral white background with a subtle cloudlike pattern in shades of pale grey.

Variation 1 Layout not recommended

Finishes 

Resistance   

Thickness 1 1/4" 3/4"

Applications interior exterior

Particularity  Always use a trivet to avoid thermal shocks & discoloration.

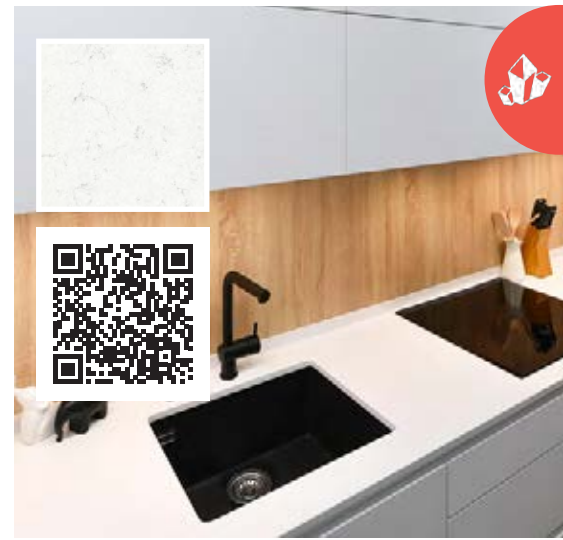

BLANCO MAPLE ( mineral surface) | Spain | Tranche : 126 x 62

The Blanco Maple features a warm white background with small to medium-sized translucent crystals that add depth.

GREY EXPO ( mineral surface) | Spain | Slab : 126 x 62

The Grey Expo offers a consistent medium grey tone with a blend of small to medium crystals in shades of paler and darker greys.

the latest trends





Dekton, a material to [re-]discover!

GRANITEDESIGN is proud of working with Cosentino, world leader and creator of the innovative Dekton surface with unsurpassed performances. Recipient of the Dekton Fabricator of the Year award on many occasions; our teams and advanced equipment shape a wide array of design concepts. Depending on your program, the availability of these colours may vary.

BERGEN ( Ultra-Compact) | Spain | Slab : 122 x 54

Inspired by the Portobello marble, Dekton Bergen aspires to perfection with shades of grey and off-white. Its sculptural movement with intense depth creates an elegant and bold statement.

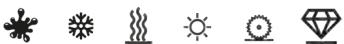

Characteristic	
Variation	3 Layout strongly recommended
Finish	
Resistance	
Thickness	20mm 12mm 8mm
Applications	interior exterior
Available edges	E M

the Dekton ULTRA-COMPACT

is a unique material that is similar to porcelain but offers many advantages such as high resistance to UV rays, temperature changes, scratches, stains, abrasion and extreme heat. This is thanks to its unique composition that has no bonding agents, and the incredible pressure that is applied to each slab (25 000 tons = 2 1/2 Eiffel Towers!)



Dekton and Edge Profiles

The Eased (E) et Miter (M) are the two available options. With the eased, the material will feature a solid color in a matte finish all along the border.

REM (Ultra-Compact) | Spain | Slab : 122 x 54 - 129 x 63

The Rem offers a soft organic texture and colors that feature warm whites, greys and caramels; inspired by the Lincoln Calacatta marble. The velvet finish reduces the contrast between the veins and the background, for a more natural look.



Characteristic



Variation



Layout strongly recommended

Finish



Resistance

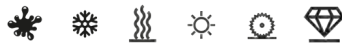

Thickness

20mm 12mm 8mm

Applications



Available edges





SOMNIA ( Ultra-Compact) | Spain | Slab : 122 x 54 - 129 x 63

The Dekton Somnia features a rich and deep background with blends of different blacks, crisscrossed by delicate and bolder veins in various shades of ivory, eggshell, copper and chocolate brown.

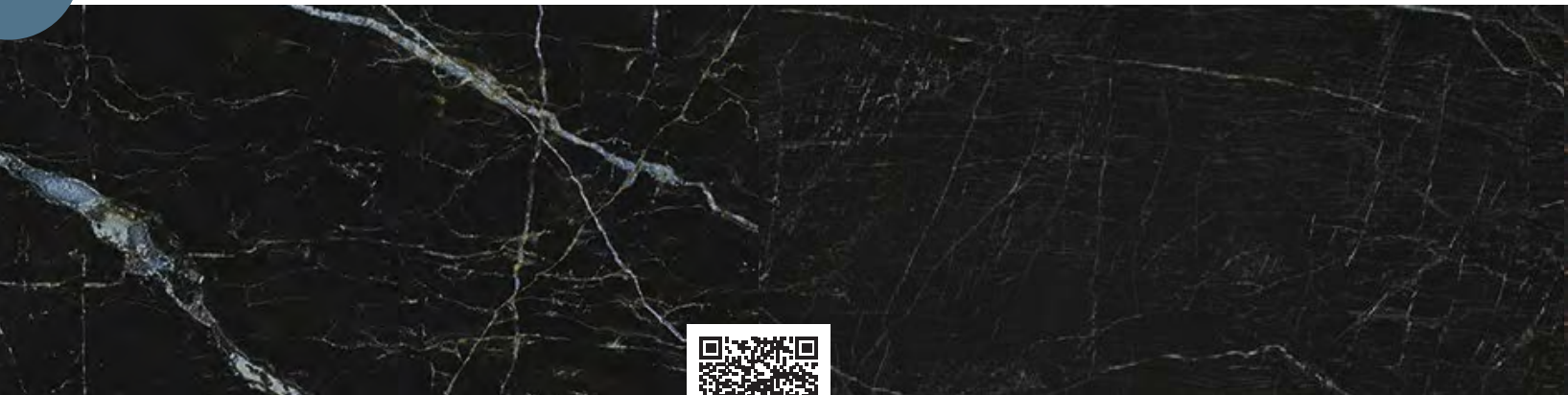

Characteristic



Variation

3

Layout strongly recommended

Finish



Resistance



Thickness

20mm

12mm

8mm

Applications

interior

exterior

Available edges





LAURENT (Ultra-Compact) | Spain

Slab : 122 x 54 - 129 x 63

The organic texture and warm tones that blend rich blacks, browns and amber are inspired by the Port Laurent marble; a dramatic yet timeless stone.

The vein texture is more pronounced than other Dektons with veins. This may result in seams and junctions between pieces to be more perceptible to the touch.

Characteristic



Variation



Visualisation fortement recommandée

Finish



Resistance



Thickness

20mm 12mm 8mm

Applications

intérieur

extérieur

Available edges



Beautiful,

these stones are inspired from natural marbles are ideally paired with rich and cozy tones.



Stainless



Brass



Raven

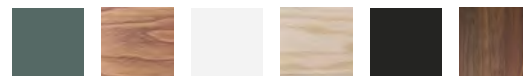



NEURAL ( Ultra-Compact) | Spain | Slab : 122 x 54 - 129 x 63

The Dekton Neural is inspired by the White Macaubas natural quartzite, with a background in pale grey tones and mostly linear veins in various shades of caramel, mossy green and pale grey. The Velvet finish reduces the contrasts between colors and adds a delicate, more natural texture.

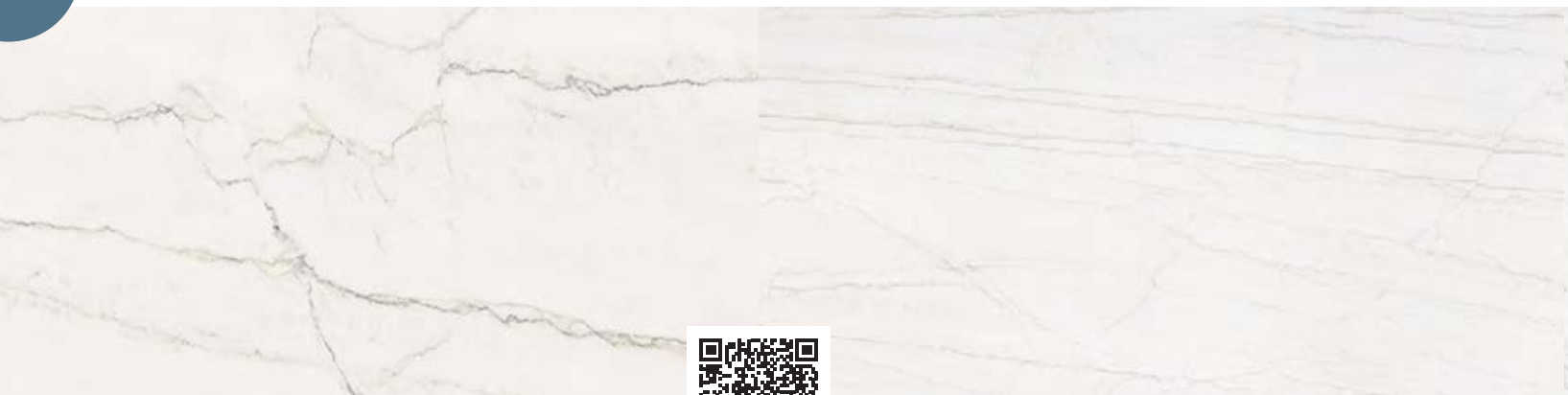

Characteristic



Variation

3

Layout strongly recommended

Finish



Resistance



Thickness

20mm 12mm 8mm

Applications



Available edges





MARINA ( Ultra-Compact) | Spain
 Slab : 122 x 54 - 129 x 63

Inspired by the whimsical salt patterns that low tide leaves on the sand and rocks, the delicate white ridges are materialized in an asymmetrical pattern of grey veins on a white base that reinterprets the classic elegance of Carrara marbles.

Characteristic



Variation



Layout strongly recommended

Finish



Resistance



Thickness

20mm

12mm

8mm

Applications

interior

exterior

Available edges



Beautiful,

these stones inspired by nature are heightened when paired with fresh breezy color schemes.



Stainless



Brass



Raven





DOMOOS ( Ultra-Compact) | Spain | Slab : 122 x 54

The Dekton Domoos features an ultra-matte finish and a cozy anthracite shade, for an elegant and timeless design concept.



Characteristic



Variation



Layout not recommended

Finish



Resistance

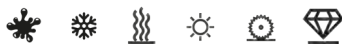

Thickness

20mm 12mm 8mm

Applications



Available edges





KELYA ( Ultra-Compact) | Spain

Slab : 122 x 54 - 129 x 63

The Dekton Kelya features a beautiful organic texture with a cozy background in various shades of black, chocolate brown and taupe with delicate veins in shades of pale grey.

Characteristic



Variation



Layout strongly recommended

Finish



Resistance

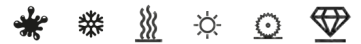

Thickness

20mm 12mm 8mm

Applications



Available edges



Beautiful,

these stones feature cozy shades that will blend with rich cozy tones or contrast when placed in luminous spaces.



Stainless



Brass



Raven













VIGIL ( Ultra-Compact) | Spain | Slab : 122 x 54

The Dekton Vigil recreates a structure inspired by the Calacatta Forte marble, with thick paler and darker grey veins, with a subtle hint of gold. The polished finish increases the contrast between the veins and the background.



Characteristic	
Variation	3 Layout strongly recommended
Finish	
Resistance	     
Thickness	20mm 12mm 8mm
Applications	interior exterior
Available edges	E M

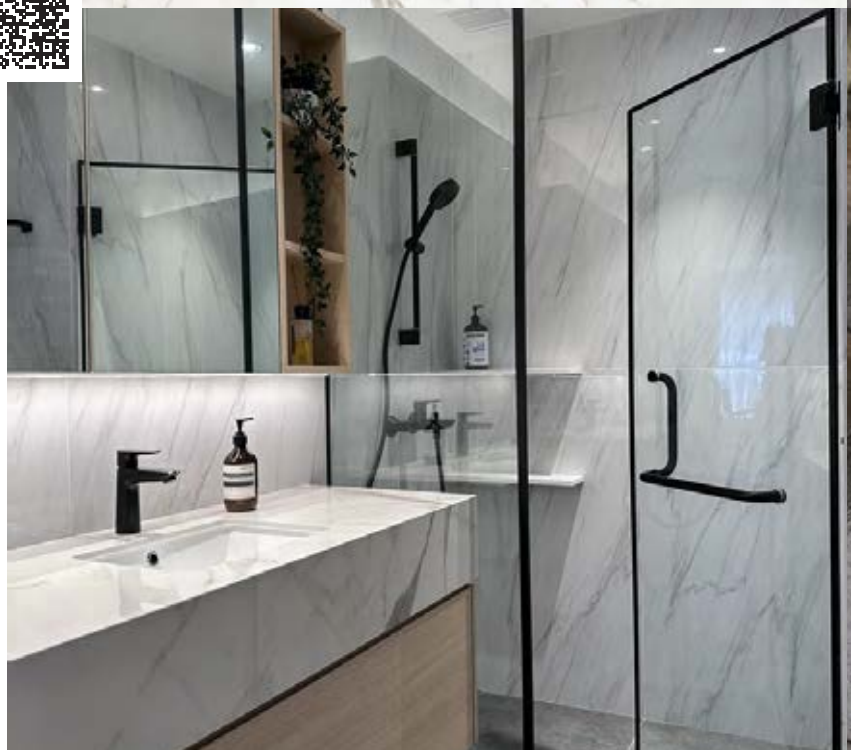



GRAFITE ( Ultra-Compact) | Spain | Slab : 122 x 54

The Dekton Grafite features earthy tones of greys and browns with a cloudlike texture in various shades of pale grey, eggshell and taupe; inspired by nature's most beautiful limestones.

Variation



Layout not recommended

Finish



Resistance



Thickness

20mm 12mm 8mm

Applications

interior

exterior

Available edges

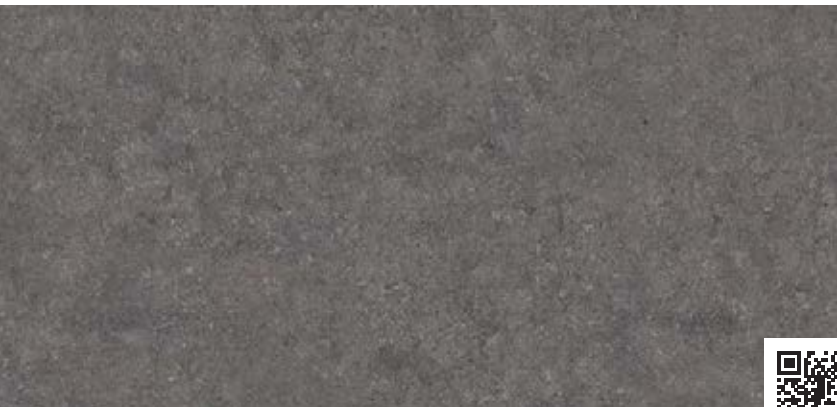

Beautiful,

and inspired by natural stones with bold personalities, they create a timeless design when paired with earthy minimalist color schemes.



Stainless



Brass



Raven











GRIGIO ( Ultra-Compact) | Spain | Slab : 122 x 54

The Dekton Grigio, with its warm grey and taupe tones, blends perfectly with cream, wood and beige color schemes. Inspired by the natural stone Grigio Alpi, a fascinating stone with macro fossils that was popularized by Renaissance architect Andrea Palladio in his Veneto villas and palaces, it will charm you by its quiet elegance.



- Variation** 1 Layout not recommended
- Finish** □
- Resistance**      
- Thickness** 20mm 12mm 8mm
- Applications** interior exterior
- Available edges** E M





Design : Cuisine Idéale Mirabel | Fabrication & Installation : Granit Design

MORPHEUS (Ultra-Compact) | Spain

Slab : 122 x 54 - 129 x 63

The Dekton Morpheus features a background of various shades of eggshell and white with contrasting veins in grey and caramel tones. The velvet texture will soften the contrasts between the veins and the background for a more natural look.

Characteristic



Variation



Layout strongly recommended

Finish



Resistance



Thickness

20mm

12mm

8mm

Applications

interior

exterior

Available edges

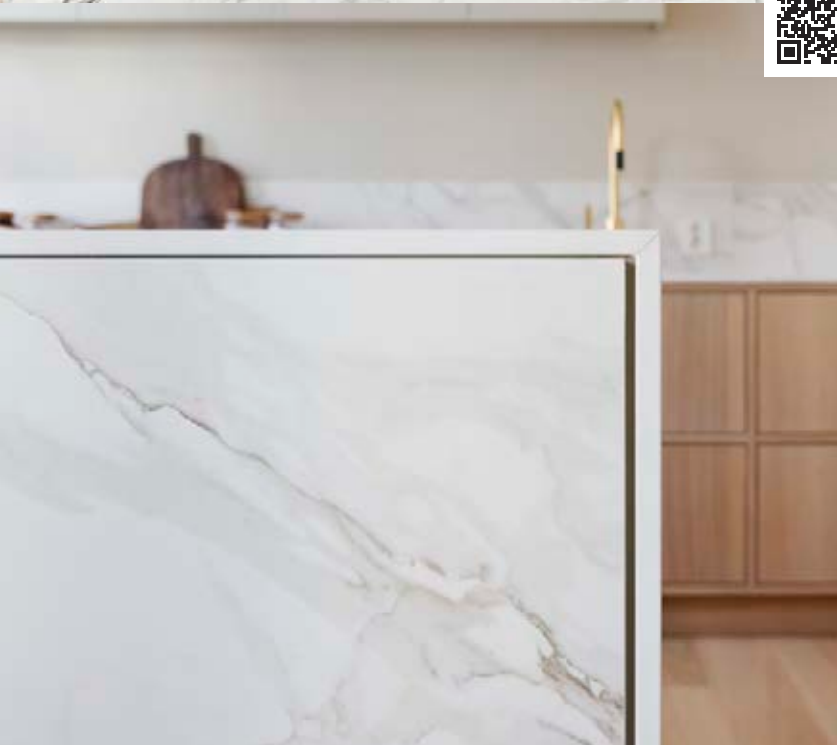

Beautiful,

and inspired by natural stones with bold personalities, they create a timeless design when paired with earthy minimalist color schemes.



Stainless



Brass



Raven



Top Selling Selection offered by Dekton

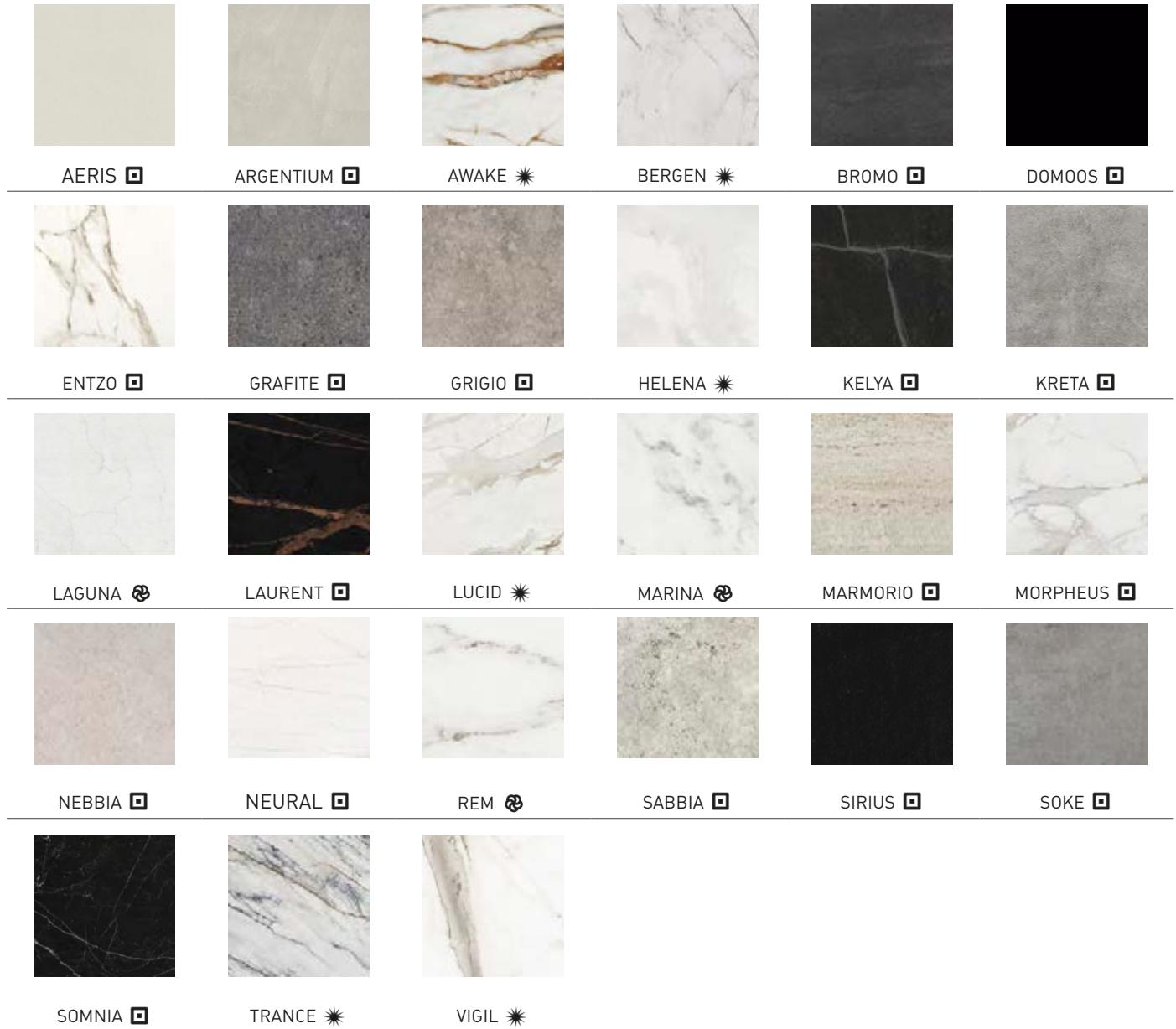

SLAB DIMENSION : Regular : 122 x 54 Jumbo : 129 x 63

FINISHES XGloss  Mat  Velour 

Each Dekton color has its own finish. We cannot transform it. Certain stones created by Cosentino have the same pattern but different finishes and are named differently (ex.: Salina and Marina; Lucid and Morpheus, Limbo and Neural).

WHEN SHOULD THE VEIN FLOW BE OFFERED?

When additional attention must be given to seams or junctions to improve vein fluidity. Ex.: a project with an oversized island and waterfall legs.



SEAMS

[PARTICULARITIES WITH DEKTON]

With Dekton by Cosentino, we recommend adding a slight tile edge on joining pieces to minimize the risks of chips during install and make care & maintenance easier; while still maintaining an elegant look.

EDGE PROFILES

[AND PATTERN / FINISH CONTINUITY]

With Dekton, because the pattern is printed on the surface of a neutral-colored bisque of high-quality ingredients, the vein continuity throughout the thickness is not often present (only a few Dekton colors offer this possibility). By choosing the Eased edge, the **edge will be honed and of a solid color**.

To avoid this situation, choose the Miter edge border with a 45-degree assembly, which will enable veins and finish continuity, and you can choose the thickness you want!



Dekton Arga - 2cm
Eased Edge
Visible beige bisque

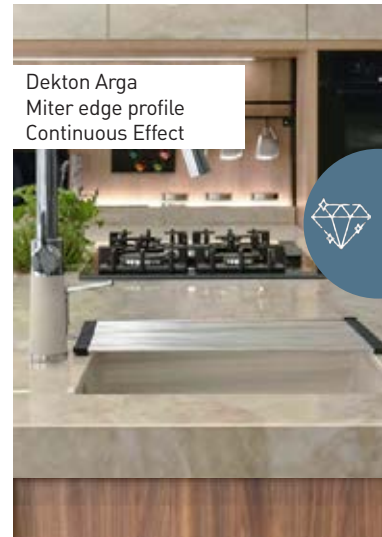

Dekton Arga
Miter edge profile
Continuous Effect



THE UKIYO TEXTURE

[BEAUTY LIES IN THE SMALLEST DETAILS]

This linear texture is possible on both Dekton and Silestone, for an elegant, clean look that adds complexity to the overall design without being overwhelming.

COSENTINO offers this texture in a selection of colors, and thanks to **GRANITEDESIGN**'s professional network, we can create this beautiful texture on any Silestone and Dekton.

working with DEKTON

a few things to consider

VARIABLE PATTERN

Certain Dekton colors are made to imitate natural stones. **In nature, a slab will contain various shades and contrasts in a random way. The same is true for Dekton. A variation in tone and the presence of impurities is therefore possible.**

For Dekton with veining or pronounced patterns, if the project includes seams in an L-shape, waterfall legs, backsplashes, etc., it is recommended to **add a layout viewing option** that allows you to see how the stone flows across the pieces and minimize break in patterns in strategic areas. Still not what you had in mind? Consider offering the **Vein Flow!**



Here is an example with Dekton Bergen showing two options. Option 1 is preferable to option 2 (but the waste might not, hence the vein flow)



The countertop must always be placed evenly on a sound structure.

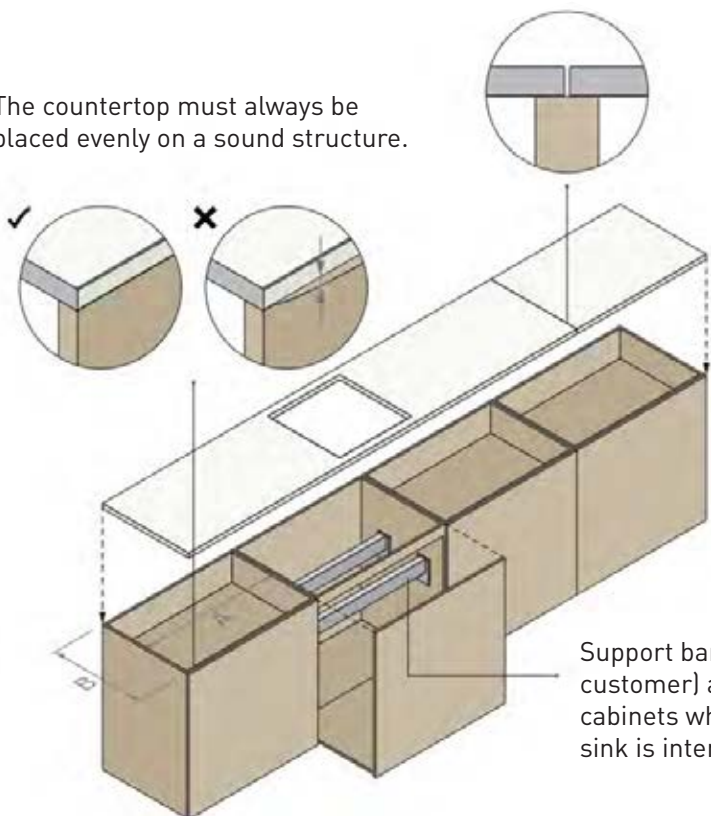

SUPPORTS and cabinets

Any appliance (dishwasher, built-in ovens, microwaves) that can generate heat must have a top made of the same material as the cabinets. This will offer superior heat protection in these areas.

Support bars (supplied by the customer) are anchored in the cabinets when a heavy cooktop or sink is intended in that area.

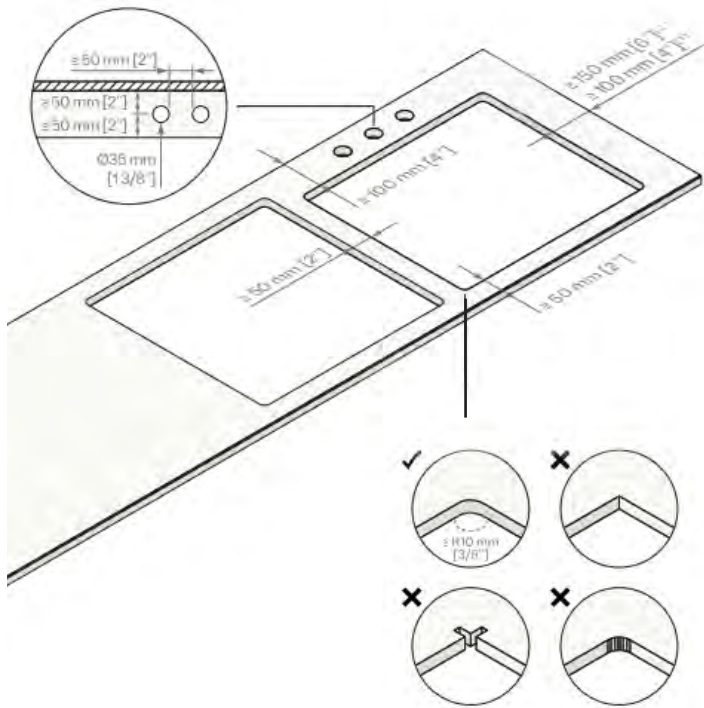

CUT-OUTS

To minimize risks of breakage, minimum piece widths must be taken into consideration when planning cut-outs. If an area is below the minimum required, it is best to create separate pieces that can be seamed.

INSIDE RADIUS

The minimum inside radius is 10mm for any cut-out in Dekton. For sinks, it is recommended to use 20mm to increase the edge's resistance. Any radius below the minimum will not be covered by Cosentino's warranty.

WATERFALL LEGS

With a material like Dekton (and Silestone), undersurfaces that are visible must be carefully planned to ensure an optimal quality installation.

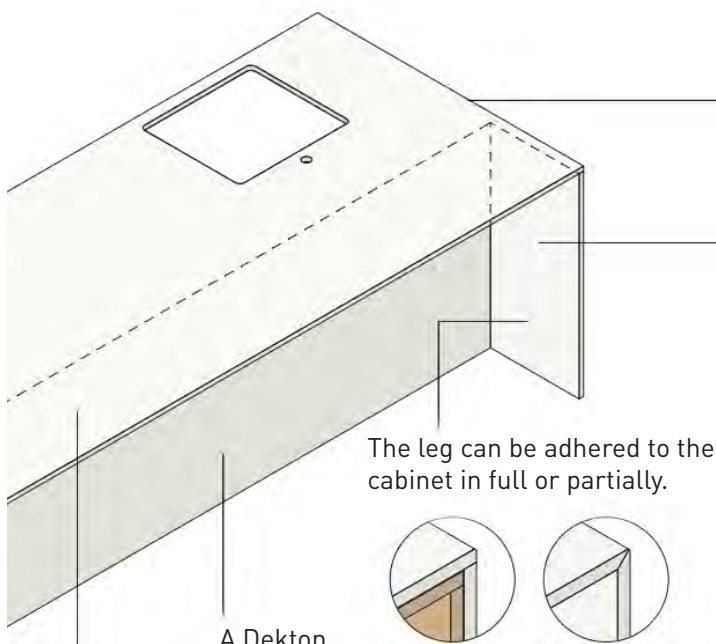

Maximum overhangs 10 to 20 inches, depending on the project's specs.

A Dekton façade must be handled like any other Dekton surface.

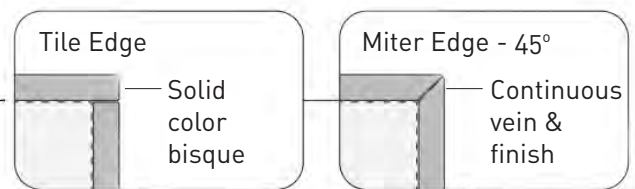

Undersurfaces can be visible depending on the project's specifications. In that case, consider:

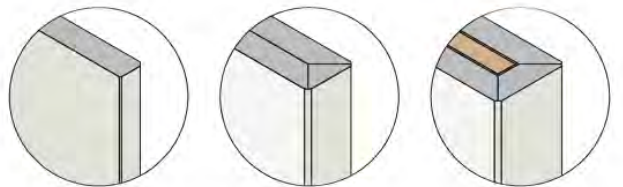

Smoothing to a honed finish to remove the branding.

The finish will never be like the top surface.

Do a return **without** cabinet.

The finish and pattern will be as the top surface.

Do a return **on** cabinet.

The finish and pattern will be as the top. The thickness will be larger than when done without cabinet.

our edge **PROFILES**

EASED

INSIDE radius CNC: 1 3/8 Manual: 1/4



FULL BULLNOSE

INSIDE radius CNC: 2 1/2 Manual: NA



BEVEL

INSIDE radius CNC: 1 1/2 Manual: 1/4



BEVEL BULLNOSE

INSIDE radius CNC: 2 1/2 Manual: 1/4



DOUBLE BEVEL

INSIDE radius CNC: 1 1/2 Manual: 1/4



WATERFALL

INSIDE radius CNC: 2 1/2 Manual: NA



PENCIL

INSIDE radius CNC: 1 1/2 Manual: 1/4



HALF-BULLNOSE

INSIDE radius CNC: 2 1/2 Manual: 1/4



HALF-MOON

INSIDE radius CNC: 2 1/2 Manual: 1/4

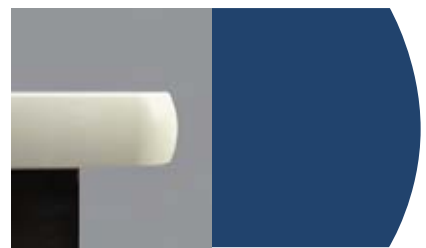

DOUBLE OGEE

INSIDE radius CNC: 2 1/2 Manual: 1/4



ROMAN OGEE

INSIDE radius CNC: 2 1/2 Manual: NA



DUPONT

INSIDE radius CNC: 2 1/2 Manual: NA



BIG OGEE

INSIDE radius CNC: 2 1/2 Manual: 1/4



SMALL OGEE

INSIDE radius CNC: 2 1/2 Manual: NA



SILHOUETTE

INSIDE radius CNC: 2 1/2 Manual: NA



SHARKNOSE

INSIDE radius CNC: 2 1/2 Manual: 1/4



MITER EDGE - 45° ASSEMBLY

Standard Thickness : 2.5 po - customizable



IMPORTANT
dimensions, radiuses
and bevels can vary
depending on machine
tolerances and the
manual pressure applied
by our artisans.

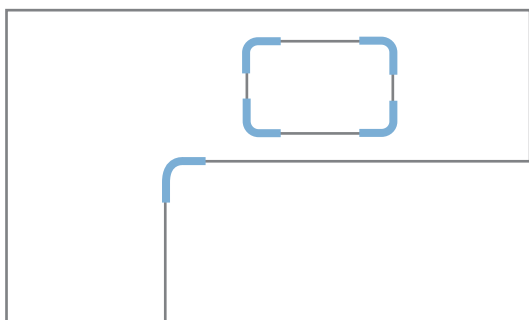

INSIDE RADIUS

[WHAT IS THAT EXACTLY]

An inside radius is found most often in sink surrounds or in an L-shaped piece that does not contain a seam.

THE CHISELLED EDGE

[AND NATURAL STONES]

This edge profile creates a rough organic look to natural stones, following the unique mineral structure. This edge is entirely made by hand.



value-added options

SURFACE COVERING

[# OP1280]

The plastic film installed by our technicians on the surface signifies that the installation was in accordance with our high standards. Technicians take photos prior and after installing the film.

From that point, if another tradesperson tears the film and damages the surface; the customer can use the film as proof to request financial compensation that will be required to restore the surface by our artisans.

IMPORTANT : this film is 4mm thick, it does not offer a protective barrier in itself. It simply indicates that at the time of install, the **GRANITEDESIGN** standards were met, and it contributes to providing elements of proof to support customers in the financial compensation process with the person who damaged the surface.



IMPORTANT
These products are **NOT** covered by any warranty.

THE STONE CARE KIT

[#P911 FULL KIT | #P910 3-IN-1 CLEANER & CLOTH ONLY]

Professional grade products ideal to maintain your natural stone surface!

IMPREGNATOR (500ml | coverage: approximately 100 sq. ft.)

Silicone-base product that penetrates the stone without altering the appearance to boost the stone's resistance to stains & UV rays. Our team of experts can also do the application (charges apply).

1. Clean and dry the surface completely;
2. Protect the surrounding surfaces;
3. Apply the product using a brush, a paint gun or a paint roll;
4. Let penetrate 10 minutes, and apply a 2nd coat before the first coat dries.
5. Remove the excess. Clean and dry the surface.

3 IN 1 CLEANER (454 g)

Your friend for natural stones, ceramic, brass, and stainless steel! Do not overuse, as it will create a build-up. This product will clean, protect and add a little shine!

HOW TO APPLY : shake, vaporize a fine coat and polish using a clean microfibre cloth until the surface is dry.



GARANTI

15

ANS*

THE EXCLUSIVE ANTI-STAIN TREATMENT

[#OP900]



Applied by our automated inspection line to ensure our worker's health & safety, but also guaranteeing an even application, a controlled curing time, and a second coat application, which will yield a superior quality barrier.

This treatment is intended for exotic natural stones.

Unlike sealers sold in stores, our exclusive GDGuard™ with long-lasting action penetrates deep into the stone and protects against food & beverage stains.



AVANTAGES

- ✓ Requires NO further sealing;
- ✓ Food Safe;
- ✓ Creates an effective barrier against liquids & oils;
- ✓ Resists heat;
- ✓ Is applied with precision (vs other fabricators who use a rag to apply similar treatments) ;
- ✓ Creates a surface that requires no special maintenance. Simply clean the surface with our daily care method!

THE CHIP MINIMIZER

[#OP1249]

Like we do with cell phone cases, this edge profile with rounded edges will minimize the risks of chips in the sensitive area around the sink.

What is a Chip?

It is a piece of the stone that breaks away from the surface after an impact, leaving behind craters.

Depending on the type of stone and size of the crater, most chips can be easily restored with little visible impact, BUT travel and workmanship fees will apply, not to mention the time off that needs to be taken to be present for the service call, and chips are NOT covered by any warranty.

Think of offering this!





SURFACE RIP-DOWN

[#OP1218]

All stones are available on the market in thicknesses considered "standard". In many cases, a same material can be available in different thicknesses, or depending on a project; a material can be ripped down during the fabrication process.

	1 1/4 in (3 cm)	3/4 in (2cm)	0.4 in (1cm)	12 mm	8 mm
NATURAL STONE	✓	✓	✓*		
MINERAL SURFACE	✓	✓			
ULTRA-COMPACT SURFACE		✓		✓	✓

* Certain natural stones are available in 1cm, slabs are generally meshed and include fibre glass to make it safe for handling and fabrication.

WHY RIP DOWN? Depending on your project, here are a few frequent reasons :

BACKSPLASHES	To ensure proper faucet functioning For a more minimalist/clean look
FIREPLACE & WALL COVERING	To lighten the load for installers (better install quality) Minimize the weight on the structure
THRESHOLDS	To free up surrounding areas To align with the rest of the floor covering thickness
KITCHEN	To lighten the weight (ex.: RV kitchens) Create a more modern look



SEAM SMOOTHER

Our inspection line validates the material's thickness, our equipment produce high quality cuts, our European seams are assembled by experienced technicians using a dual-vacuum system to create the nicest seams possible, **so why choose this option?**

- ✓ To add time to your installation that allows greater care and a full review with our technicians specifically for the seam area;
- ✓ To add an additional insurance; as this option also includes the first service call for a situation relating to a seam following installation.

With or without the Seam Smoother, **GRANITEDESIGN** respects quality standards:

QUALITY STANDARDS - related to a seam		
Height between two pieces at a seam (can be visible and can be felt)	1/32"	
Thickness of the seam between two pieces (including the micro-chip area)	1/8"	

Industry standard



WITH seam smoothing
the final result may vary depending on material.



**1-YR
WARRANTY**

Covers seam performance and undermount sink installation. Following 1 year, any ungluing, opening or seam popping related or not to structural change, misuse or abuse of the surface is not covered. The esthetic aspect of a seam is never included in the 1-yr warranty, except if the seam does not respect industry standards. The silicone finishing between a countertop and a wall is not a seam and never covered by the warranty.



CUSTOM UNDERMOUNT CUT-OUT

[#OP1228 - KITCHEN | #OP1230 - VANITY]

The undermount cut-out is installed in overhang to ensure an easy maintenance in areas that are prone to bacterial propagation. It also creates a cleaner look that takes into consideration the sink fabricator's tolerances.

SPECIFICATIONS

- ✔ Cut and polished on our CNC machines;
- ✔ The eased edge profile is standard, but can be personalized with the Chip Minimizer, bevel, pencil, small ogee or dupont edge;
- ✔ Overhang installation is recommended for a more pleasing and easy to care result;
- ✔ Generally has a 3/8" inside radius (will vary depending on chosen material and edge profile)

What happens to sink cut-outs?
Find out at 0:38!



OVERHANG - by default

The countertop exceeds the sink by 1/8" to 3/16".

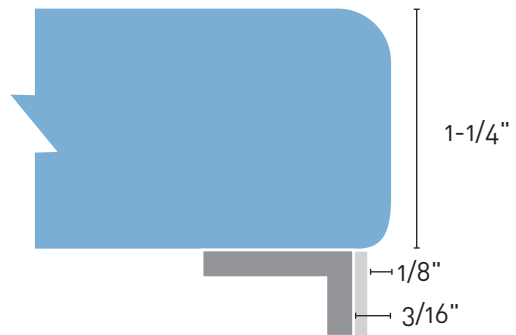

FLUSH

Difficult to obtain perfect result, as sink makers have min/max tolerances in specs.

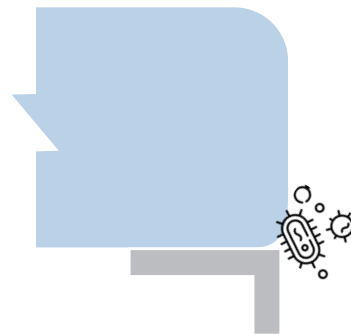

REVEAL

Not recommended, the surround is visible and prone to bacteria accumulation.



DRAINBOARDS

A drainboard will optimize space and offer an elegant solution in lieu of the ugly dish racks. With this option, water will trickle down, but do not expect a waterfall [the slope is not that intense!]

Models are



SLOPED RECESS	FLAT RECESS WITH FLUTE	FLUTE	FLUTE + RING
✔ Natural Stone	✔ Mineral Surface	✘ Dekton	✔ Natural Stone
		✔ Natural Stone	✔ Mineral Surface
			✔ Dekton*

PARTICULARITIES PER MATERIAL TYPE

SOLID GRANITE & MINERAL SURFACE	EXOTIC NATURAL STONES (VAR. 3 & 4)	*DEKTON
Good choice	Microfissures will be visible, change in color in flutes possible (through oxidation). Seal yearly.	Flutes will not have the printed design and will be honed. Will require more frequent cleaning.



different backsplashes



Taj Mahal antique finish
Fabrication & Installation : Granit Design

CUSTOM-HEIGHT

STANDARD HEIGHT

FULL HEIGHT

BACKSPASHES

Particularly with exotic natural stones with high variation or mineral & ultra-compact surfaces with veins, it is important to plan the backsplashes at the same time as the countertops, and offer the layout option.

	STANDARD	CUSTOM	FULL HEIGHT
HEIGHT	Generally 4 in. Can be different, as long as it is the same height throughout all backsplash pieces.	Height to fit surrounding elements (windows, ceiling, etc.)	16 to 18" to fill the space between the countertop and upper cabinets
THICKNESS	1-1/4"	1-1/4" Rip down to 3/4" recommended	1-1/4" Rip down to 3/4" recommended
MAX LENGTH	48 - 60" (natural stone) 80" for mineral & ultra-compact surfaces		
EDGE	Generally eased, but can be customized		
ADJUSTMENT	Adjustments on-site can be required to ensure a quality installation.		
SEAMS	Any seam in a backsplash will always be visible and perceptible to the touch. A slight tile edge will be included to facilitate installation.		

SIDE SPLASHES

Creates a transition between an area with a full-height backsplash and surrounding walls. Here are some popular examples.

Side splashes are subject to the same specifications as backsplashes.



THE TILE EDGE

Featured with full-height backsplashes or wall panel projects (fireplace, shower, etc.), it ensures a quality installation and eases care & maintenance. Depending on the project, our experts choose the appropriate tile edge.

Flat Tile Edge
Polished edge

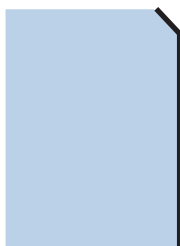

Tile Edge
polished bevel only

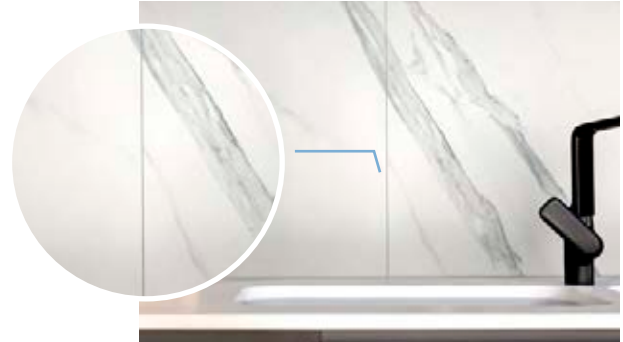
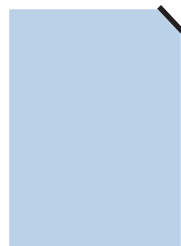

ARCS & BUMPOUTS

[#OP1231]

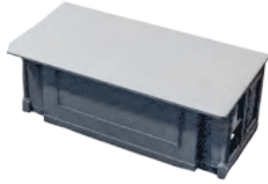

OVERHANG

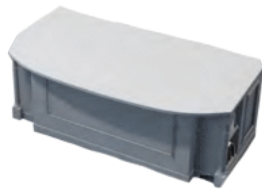

ARC



BUMPOUT



SPECIFICATIONS

- ✓ Generally used in an island or in front of a sink;
- ✓ Material calculation must include the waste created by the cut;
- ✓ For overhangs and arcs, the standard overhang without support must be respected depending on the chosen material.

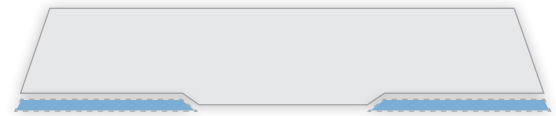

Ex. of material calculation that takes into consideration the waste created by the bumpout cut.

COUNTERTOP OVERHANG

Standard countertop overhang without required support is generally between 10 and 12 inches. This can vary on the material's type and thickness. We give as general rule of thumb the 2/3 - 1/3 rule (2/3 supported by cabinets for 1/3 unsupported).

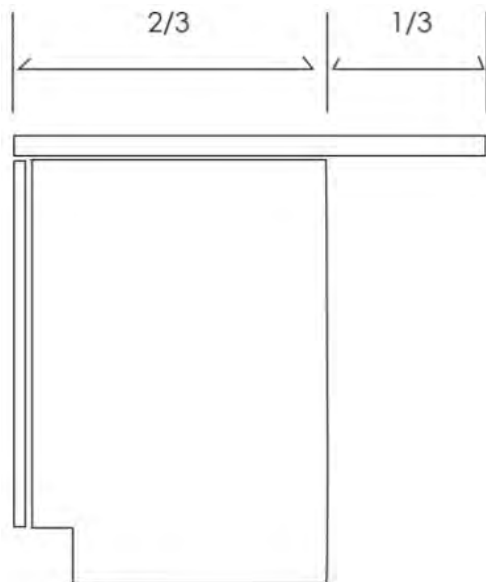

As soon as the unsupported surface exceeds that proportion, support is required.

In the event of a large overhang behind a sink or cooktop, a hidden support will be required and installed by our technicians. If the proportion beyond cabinets is considerable, it is possible that other support types (corbel, leg, brackets) are required.

If your design includes brackets or other, they must be on-site for the measure.

MAXIMUM OVERHANG WITHOUT SUPPORT

1 1/4" Granite <i>variation 1 & 2</i>	15"
1 1/4" Exotic Granite <i>variation 3 & 4</i>	12"
1 1/4" Marble/Quartzite	12"
1 1/4" Soapstone	12"
1 1/4" Mineral Surface	12"
3/4" Ultra-Compact	10"



your options for radiuses



Large radiuses are back, with the timeless Mid-Century-Modern style that is more popular than ever! Here is a radius sizing chart of the most popular options, to help you better target customers desires!

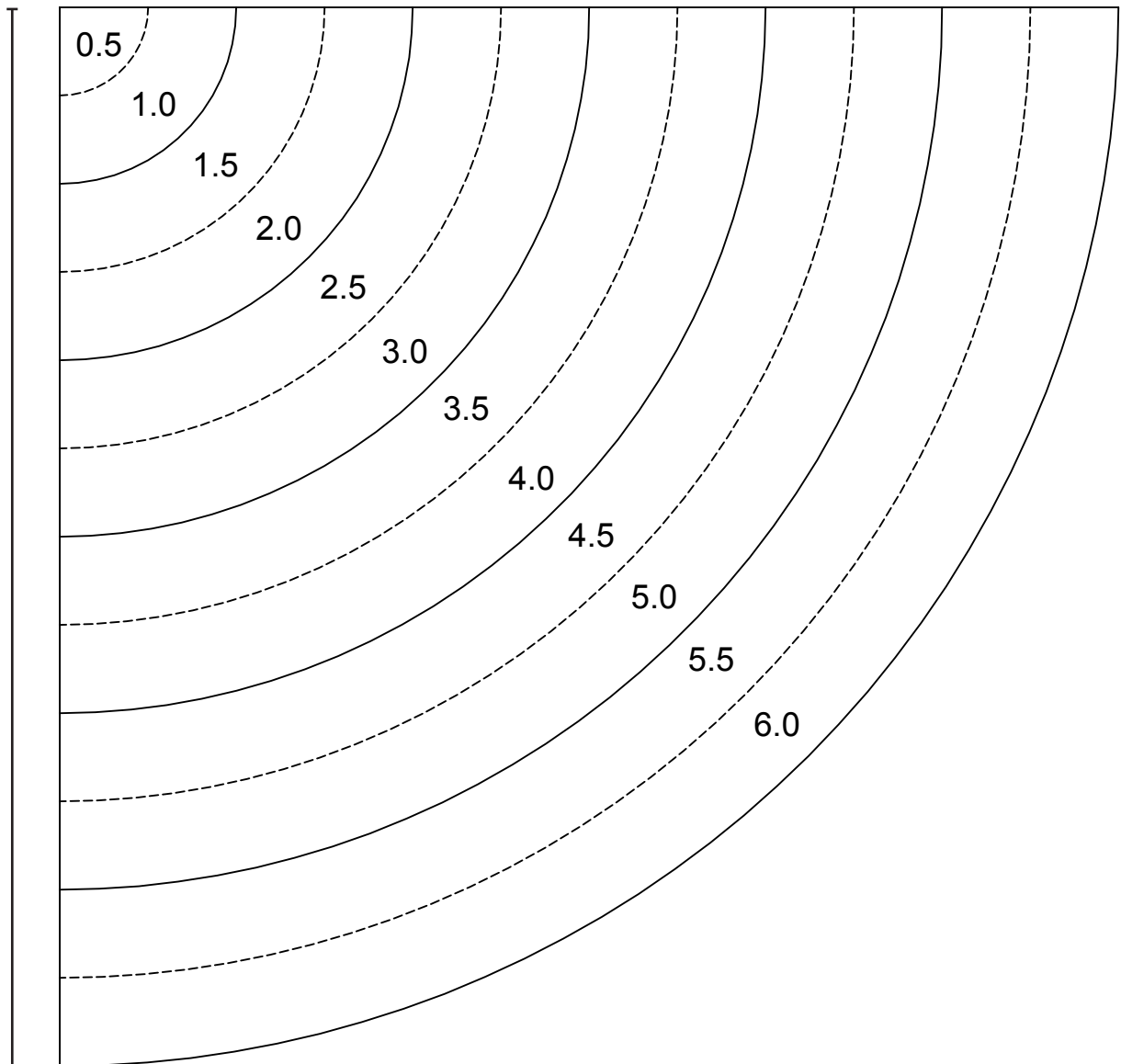

ONCE PRINTED
this chart
should
measure 6
inches to be
to scale.

BRACKETS AND OTHER SUPPORTS

Brackets and other support (corbels, legs, metal invisible plates, etc.) are important to plan when an overhang exceeds the safe maximum width without support.

SPECIFICATIONS

- ✔ The purchase is a customer's responsibility;
- ✔ The support must be in place, fixed to the cabinet for template (except for PerfectF.I.T.™ projects where they should simply be on-site);
- ✔ Installers will fix the top portion to the countertop as that step is more delicate and requires to take the stone's unique nature in consideration.

BRACKET/CORBEL	LEGS	AVERAGE MATERIAL WEIGHT (per square foot)	
A 24-inch distance between each is recommended.	For overhangs of 18-in and more.	1 1/4 Natural Stone	18-20 lb
Ideally install support to the cabinet prior to template.	Must be sufficiently sound to support the stone's weight.	1 1/4 Mineral Surface	20-25 lb
	30-in distance recommended.	3/4 Ultra-Compact	12 lb



WATERFALL LEG

[#OP1259 - 45-degree assembly | #OP1260 - tile assembly]

This European trend is now mainstream. The 45-degree assembly offers a "seamless" look that wraps the surface. The tile assembly creates a visible junction, but will provide a cost-effective option with an elegant result.

SPECIFICATIONS

- ✔ Leg sold per unit;
- ✔ Pieces are dry-fitted at the fabrication facility, and assembled on-site;
- ✔ Cabinets must be created to allow flexibility at installation (especially if there are legs on both end);
- ✔ Think of offering undersurface polishing when undersurfaces are visible. The polish will match the top's finish (for polished and honed stones), and for an antique stone, the undersurface will be honed.

45-degree Assembly
"Seamless" look



Tile Assembly
Visible junction



Offset Leg Option
can add flexibility in the ways of using the space.





LAYOUT VIEWING

This document is used to better imagine how a stone's pattern will run across the different pieces of a project. This service is recommended for natural stones, mineral and ultra-compact surfaces that have high variation. Additional fees may apply depending on the selected stone; make sure to ask about the option!

IMPORTANT TO CONSIDER

- ✔ Certain factors in production can have an impact on the final result;
- ✔ When one observes the fluidity between countertop and backsplash pieces, a perfect match in veining is not achievable, as the saw blade and material thickness combined will result in vein offsetting. The result will remain esthetically pleasing.
- ✔ With the basic layout option, production planning uses the material maximization technique to offer our partner distributors and their customers the most advantage price possible. If the customer desires an optimal fluidity than what is achieved through this option, consider the Vein Flow.

EXAMPLE : Version A was rejected to change material. Version B was accepted and installed.

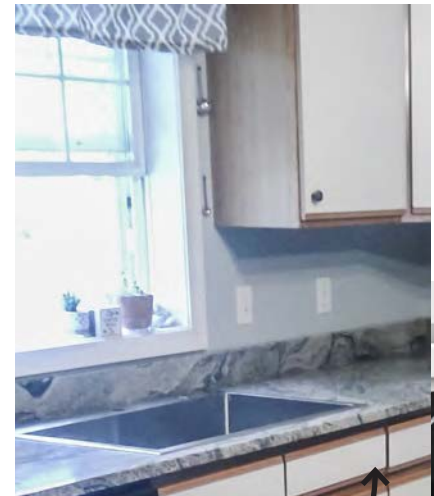

Installed
as planned!



UNDERSURFACE POLISHING

When an undersurface is visible, we recommend offering the undersurface polishing, which will result in the matching the under surface's finish to the top (for the polished and honed surface). A top with an antique finish will have a honed undersurface finish.

Without this option, the surface underneath will be rough, may have meshing (for natural stones) or brand markings (for mineral & ultra-compact surfaces).

OFFER THE OPTION when a project has

- ✔ A raised bar;
- ✔ A countertop with waterfall legs and an overhang;
- ✔ A countertop with an overhang with seating.



POLISHED UNDERSURFACE



NON-POLISHED UNDERSURFACE

THE VEIN FLOW

When designing a concept, it can be good to add a vein flow option, but especially; it is important to prepare customers and manage their expectations which are often too high (thanks to the Magazine Cover page effect, where most photos are edited to hide certain «flaws»).

The base price means that our team will plan each piece in a way that minimizes waste while offering the most pleasing result. **The Vein Flow option means that our team will prioritize vein fluidity even if it means purchasing more material and increasing waste on the project.** Even with the Vein Flow option, veins may not match up perfectly everywhere, but the result will be the best outcome possible.

OFFER THIS OPTION when a project has

- ✔ A backsplash that is made of the same material as the countertop (especially if the chosen material has veins)
- ✔ Island with waterfall leg
- ✔ If the vein fluidity across different pieces is more important to the customer's eyes than the bottom line cost.

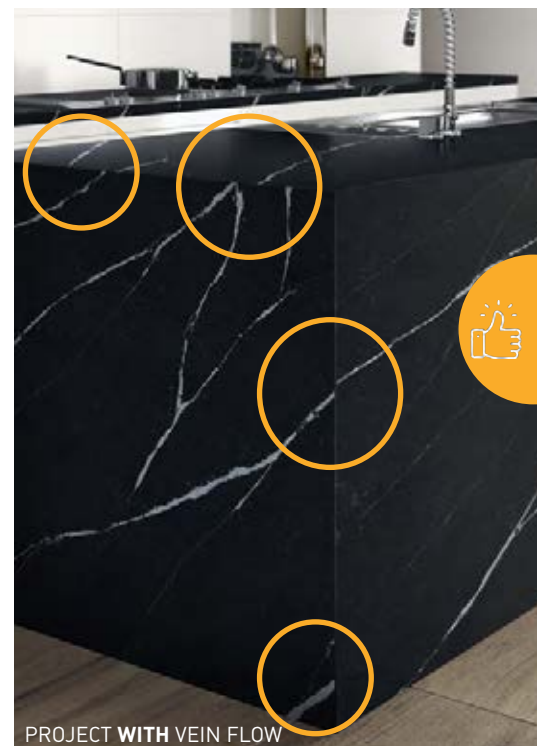

PROJECT WITH VEIN FLOW



✗ EXPECTATIONS



✔ REALITY

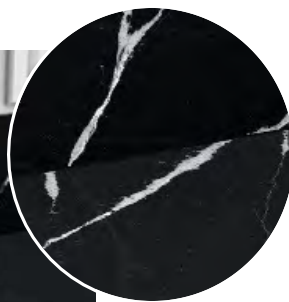

TOP VIEW
as planned at cutting

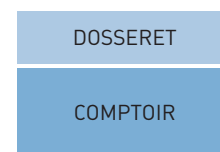

SIDE VIEW
once installed

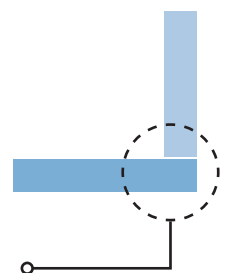

A portion of the countertop is hidden by the backsplash. Veins will be offset, but the result will be pleasing.

creating an outdoor oasis

Dekton Ceppo | Design : Armoires Cordeau | Fabrication & Installation : Granit Design



Plancher Dekton Laurent, comptoir & dossier Dekton Sirius
Fabrication & installation: Granit Design



TAKING ADVANTAGE OF THE BEAUTIFUL SEASONS

Many materials are appropriate and will create an elegant and durable surface [yes, even with our Canadian winters!].

Whether it be to create a BBQ area, a full outdoor kitchen, a beautiful fireplace where we can chill, choosing the right material for a customer's budget and lifestyle is the first step.



Share this article with your customers!



- Ultra-compact (Dekton)
- Solid colored granite
(variation 1, dense minerals, less resin)
- Exotic granites
(variation 2, 3 & 4, mixed minerals, resined)
- Soapstone
- Quartzite & Marble
- Mineral Surface*

❄️	☀️	🔥	❄️	
✅	✅	✅	✅	😊
✅	✅	✅	✅	😊
✅	✅	✅	✅	😊
✅	✅	✅	✅	😊
✅	✅	✅		😊
✅	❌	❌	❌	😞

* certain mineral surface options can be used outdoor, make sure to ask!



we are much more
than countertops

Estuario | Fabrication & Installation : Granit Design



Dekton Rem |
Fabrication & Installation : Granit Design

OVER A QUARTER OF A CENTURY OF EXPERIENCE...

is at your disposal to create the custom design of your dreams. Whether it be a master spa inspired bathroom, a stunning fireplace, custom-made tiling, custom-made stone sinks, or furniture intended to the residential, commercial and institutional market that will be as elegant as they are durable, our passionate artisans know how to transform stone.

[Does it happen just like that, first try?] - often yes; sometimes no.

Stone is a unique material to work with, that comes with particularities that will differ. More a project is complex, more these particularities come into play, must be considered carefully and the time required must be taken at each step.

[But will we be there to support you until the customer is fully satisfied?] - YES, without a doubt!



Dekton Bergen |
Fabrication & Installation : Granit Design



Dekton Kelya & Cambrian Black antique
Fabrication & Installation : Granit Design



Dekton Galema |
Fabrication & Installation : Granit Design



Dekton Domoos |
Fabrication & Installation : Granit Design

choosing the right sink



Silestone Grey Expo | Design : Armoires Cordeau | Fabrication & Installation : Granit Design

THE IMPORTANCE OF AN EDUCATED CHOICE

The sink is an important part of any concept. The size, positioning, accessories, available space, there are all factors that will guide the customer towards a choice that will suit their needs.

AVAILABLE SPACE		MATERIAL		INSTALLATION TYPE	
Cabinet width	Maximum Sink Width	Type	Description	Type	Description
24 in.	21 in.	Stainless	Simple to install & maintain ; Antibacterial ; May require special cleaners.	Undermount	Applied under the countertop; No visible border; Easy maintenance.
27 in.	24 in.				Must be left in place 24h before connecting the plumbing.
30 in.	27 in.			Drop in	Visible border;
33 in.	30 in.				Plumbing can be connected right after installation (under customer's responsibility).
36 in.	33 in.				Silicone bead can be added (under customer's responsibility).
		Natural stone, mineral or ultra-compact surface	Elegant, resistant & can be repaired; As resistant to scratches as a countertop; Cabinet must be able to withstand the weight; Require same type of care as countertops; Lifetime warranty against leaks.	Apron (farmer)	Bowl with visible facing; Must be in the cabinet at template, but not permanently fixed.

Une cuve, ou deux?

Typiquement, une cuve simple est recommandée pour les espaces restreints. Par contre, il existe des cuves simples surdimensionnées qui sont tout aussi pratiques qu'une cuve double, allez-y selon vos goûts !



MINIMUM CLEARANCE		
at the front of the sink	at the back of the sink	at the back of the faucet hole
3.5 in.	5 3/4 in.	2 1/2 in.*

* remember to consider the backsplash thickness into the calculations!

IMPORTANT
Undermount sinks are installed by GRANITEDESIGN using a high-performance adhesive, and the adhesive performance is guaranteed for 1 year following installation. The technician will NOT reconnect plumbing, especially with undermount sinks as the adhesive requires 24 hours to fully cure.



CUSTOM-MADE STONE KITCHEN SINKS

Fabricated in natural stones, mineral or ultra-compact surfaces, our sinks are built by artisans using the tongue & groove technique to the desired dimensions.

NEW ENGLAND
#MM1002

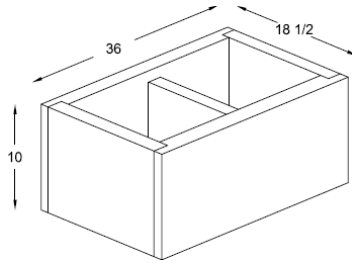

BOSTON WILLIAM
#MM1000

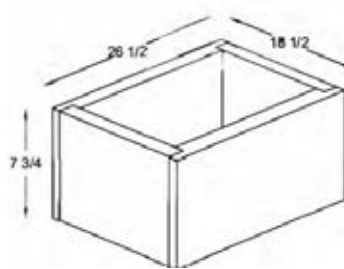

CHICAGO
#MM1003

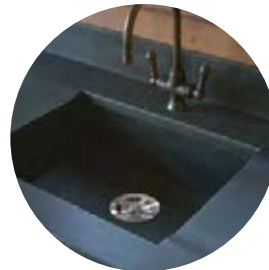
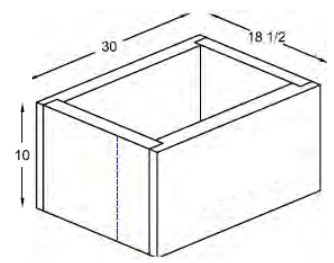

Our custom-made sinks have a lifetime warranty against leaks.

CUSTOM-MADE STONE VANITY SINKS

Whether it be natural stones, mineral or ultra-compact surfaces, each vanity sink is built by our artisans and assembled with great care to provide a high-quality product.

ARMONY
#MM1020

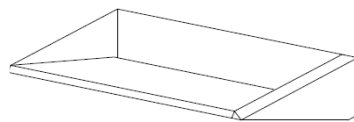

Suggested Dimensions:
30 in. x 12 in. x 7 in.
(76.2 cm x 30.48 cm x 17.8 cm)

FONDO
#MM1015

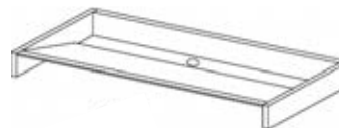

Suggested Dimensions:
42.25 in. x 9.75 in. x 5 in.
(107.32 cm x 24.77 cm x 12.7 cm)

PLAZA
#MM1010*

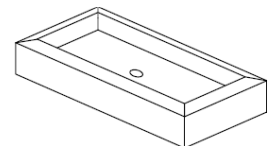

Suggested Dimensions:
24 3/8 in. x 12 in. x 4 in.
(61.91 cm x 30.48 cm x 10.16 cm)
* modèles : #MM1010 - vasque
#MM1010 - intégré
#MM1010 - sous plan

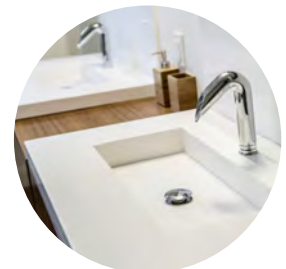
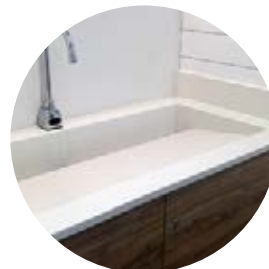

Our custom-made vanity sinks are quoted with our pop-up drain kit BS-03. If the customer wishes to use his own model, simply inform our team and ensure the desired model is on-site at template.



INTEGRITY SINKS

Fabricated in mineral surfaces, these sinks offer all the same advantages that have made Cosentino's Silestone surface a worldwide leader; creating a durable and easy-to-maintain sink.

This option allows to create a seamless look that is easy to install. The Integrity sinks are available in different colors and in three sizes :

DUE (S)
#MM1017



14.56 x 13.38 5.9 in.
37 x 34 x 15.5 cm

DUE (L)
#MM1018



14.56 x 20 x 5.9 in.
37 x 51 x 15.5 cm

DUE (XL)
#MM1019



16.93 x 26.378 x 8.27 in.
43.5 x 67 x 21 cm



STAINLESS STEEL SINKS

Your pots and pans are no match to the durability of our sinks! Our collection offers high quality, durable models in different sizes, providing an option for every space.

Model availability can vary, validate with our team prior to ordering!

SMALL SINGLE BOWL [a little something extra]

Ideal for outdoor kitchens, as bar sink, or as additional sink in a kitchen's prep station.

Its rounded corners make it a breeze to clean!

SINGLE BOWLS [perfect anywhere!]

The selection offered by **GRANITEDESIGN** has something for everyone!

Whether it be more traditional rounded corners or more modern, minimum radius corners, we have the model for you!

DOUBLE BOWLS [when you need more!]

Ideal for larger spaces, the **GRANITEDESIGN** collection has both rounded edge models and more modern, minimum radius corners.

Locate our sink models and specs on our website!



Upgrade a concept with a vanity

WHEN CREATING A CONCEPT

It can often be beneficial to a customer to use the material and create simultaneously to a kitchen project smaller pieces such as vanities, mudroom seating, shelves, thresholds, etc.

You have a smaller project, and your customer is flexible on the material? Speak with our experts who can offer you the best solution possible!

WHITE PORCELAIN VANITY SINKS

CHU1512 WH

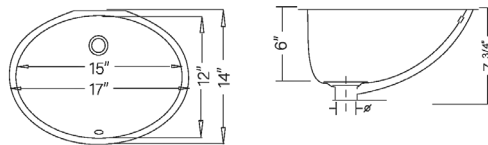

CHU1714 WH

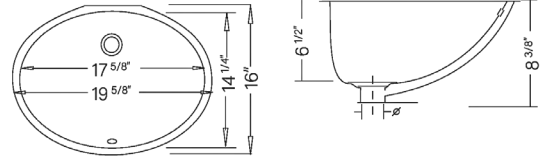

CHU1612 WH

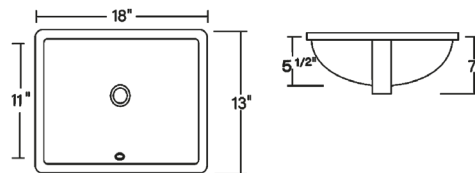

CHU1913 WH

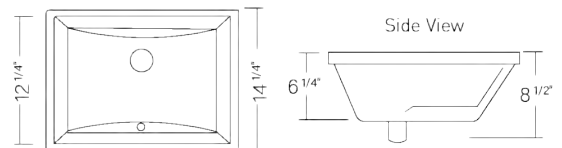



POP-UP DRAIN KIT

[#BS-03]

This drain kit offered by **GRANITEDESIGN** is compatible with all porcelain sinks! Think of adding it to your order!

Our expert advice!

HOW TO CALCULATE A SURFACE

Let's go back to basics. First, make sure to have the plan with dimensions in inches. Divide the plan into plain shapes (rectangles). Let's take this L-shaped countertop with 4-inch backsplash (identified with the ) and an eased edge profile (identified with the ):

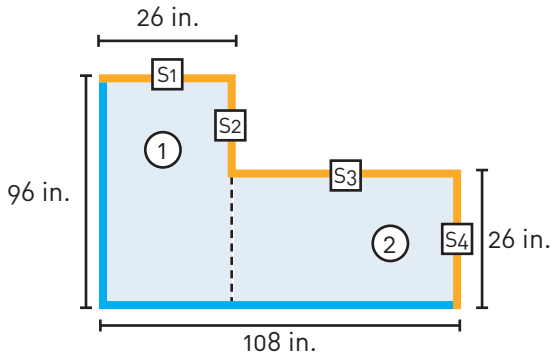

CALCULATE THE SQUARE FEET

[for countertop & backsplash surfaces]

1 $26 \times 96 = 2496 \text{ in.} / 144 = 17.3 \text{ SF}$

2 $82 \times 26 = 2132 \text{ in.} / 144 = 14.8 \text{ SF}$

#1: $96 \times 4 = 384 \text{ in.} / 144 = 2.7 \text{ SF}$

#2: $108 \times 4 = 432 \text{ in.} / 144 = 3 \text{ SF}$

$17.3 + 14.8 = 32.1 \text{ SF}$

$2.7 + 3 = 5.7 \text{ SF}$

TOTAL MATERIAL : 38.1 SF

CALCULATE LINEAR FEET

[for edge profiles]

$26 + 70 + 82 + 26 = 204 \text{ in.} / 12 = 17 \text{ LF}$



WHY 26 INCHES?

Because a standard cabinet is 25 inches deep, and we recommend a 1-inch overhang.

CALCULATING THE NUMBER OF SLABS

To estimate the number of slabs required for a project using maximization methods, here is a chart that provides the slab average size per material type. In these dimensions, we reduced a safety margin. This is why they differ from material fabricator websites (ex.: Cosentino). It is important to understand their sizes are gross, and edges are rarely perfect, the safety margin is necessary to cut away any imperfection (this is why you cannot plan a 120-inch wide piece in a slab that shows 120 inches wide..!)

SLAB DIMENSION			
Granite (average)		116 x 65	
Marble (average)		115 x 60	
Quartzite (average)		116 x 68	
Soapstone (average)		118 x 65	
Mineral Surface	Reg.: 119 x 53	Jumbo : 126 x 62	Jumbo + up to 129 x 63
Ultra-compact	Reg.: 122 x 54	Jumbo : 129 x 63 (check availability)	



ATTENTION

These dimensions will vary. Mother Nature does not create perfectly even blocks!

ONLINE INFORMATION

Our website will allow you to :

- ✓ See popular stone choices
- ✓ Check out sink models and specs
- ✓ Chat with an agent (yes, a real human and employee!)
- ✓ Read interesting articles
- ✓ Admire recent installations
- ✓ Order samples (designer only)

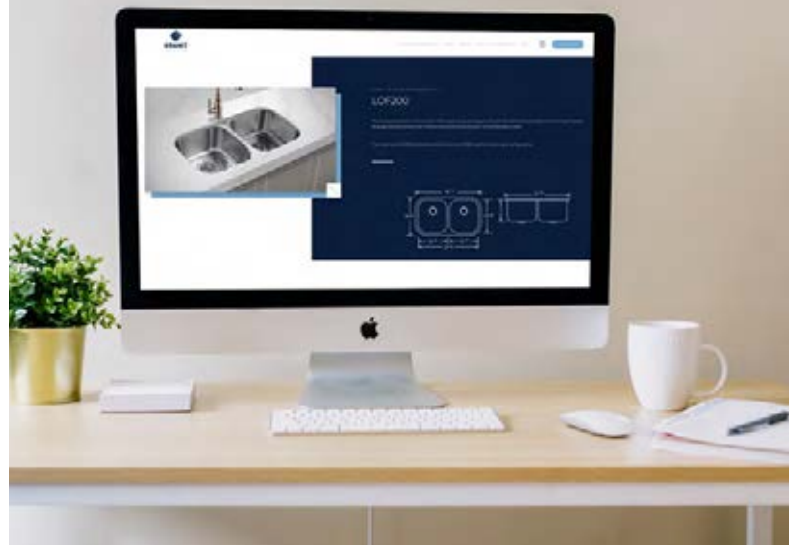

Get started!
Visit GRANITEDESIGNUSA.COM



your partner CONNECTION



RESERVE INVENTORY

Will bring you to e.cosentino.com, to see available inventories and full-slab images (natural stones) at the Cosentino Quebec warehouse.

My username:

My password:

SURFACE HARDNESS

Invented in 1812 by German mineralogist Freidrich Mohs, this scale still is used today to measure mineral hardness on a scale of 1 to 10 (1 being less and 10 being very resistant to scratches).

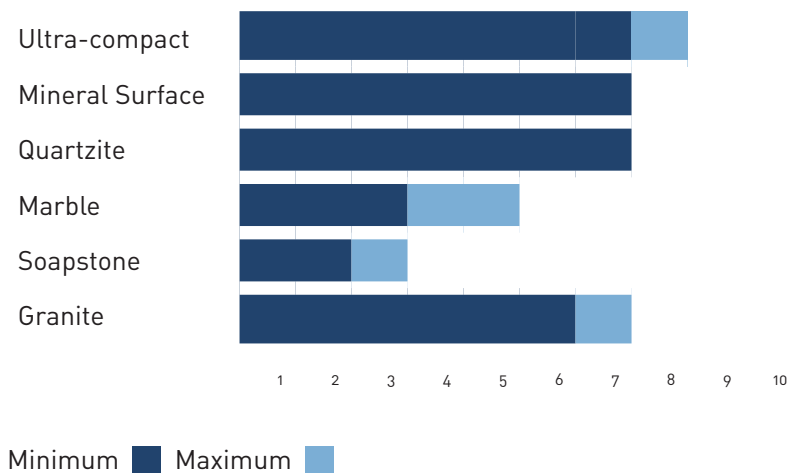

the « scratch »
test

A material with a level between 2 and 2.5 will be scratched with your fingernail. Materials with a 5 will be scratched with a steel blade.

Dare to do the test!
[but maybe not on a customer's countertops!]



INSTALLING FULL HEIGHT CABINETS

Full height cabinets are coming back! Did you know that you do not need to schedule two separate appointments to have these cabinets installed? Simply allow the necessary gap between the bottom & top portion to fit your countertop material!

MATERIAL TYPE	SPACING
1 1/4 in. Natural Stone	1 3/8
1 1/4 in. Mineral Surface	1 3/8
3/4 in. Mineral, Ultra-compact or natural stone surface	7/8



STONE SURFACE INSTALLATION - INDUSTRY STANDARDS

Each project is unique, as is each installation space. Many variable factors will impact installation (home's age, wall & floor level, etc.). To ensure a high quality installation, it is possible that technicians adjust surfaces on site, and it is normal! There are also industry tolerances to consider:

Seams : a few epoxy coats can be required. A height difference between two joining pieces of 1/32 is tolerated.

Level : cabinets must be level and coplanar on a 10-foot run. Shims can be used. If the situation requires more correction, the technician will offer solutions; or will inform the customer that installation will need to be postponed to allow adjustments to the cabinets.

Flush installation : we do not recommend to install countertops flush with cabinet doors. A minimum of 1/4 inch overhang is required, and the optimal overhang is 1 inch.

Spacing : A 1/8 space between the countertop and the wall is required to allow for structural shift. We also leave between 1/8 and 1/4 inch between the top of the backsplash and top cabinets for full-height backsplashes for that same reason.

Chips & scratches : a surface can require adjustments at installation to correct superficial chips and scratches that can occur during transportation and piece handling. This is not a defect, **our technicians must be granted the opportunity to address the situation** to the customer's entire satisfaction. It is important to differentiate a scratch/chip from a microfissure (see page 7).

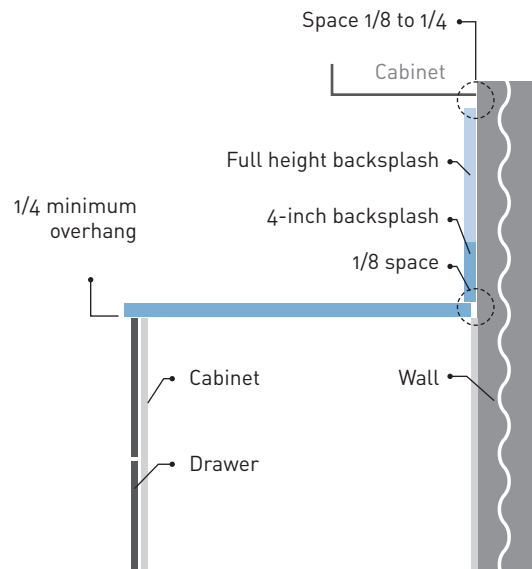

Side view - installing a countertop

ATTENTION

The silicone finishing is optional, to the technician's discretion, and is not a seam. A 2nd coat is often required and must be done by the customer.



SEAM TYPE AND PLACEMENT

The invisible seam does not exist! It's rock, that is cut, then glued back together. However, the level at which the seam is visible will vary from one fabricator to another. **GRANITEDESIGN** prides itself on our superior quality seams :

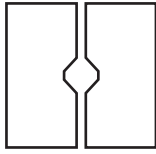

Joining pieces are fabricated with a V-Groove (for superior adhesive penetration)

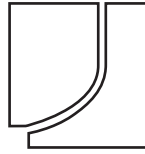

European seams are prioritized for an optimal result.

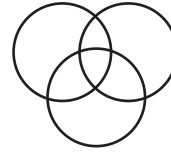

High quality color-matched adhesives are used.

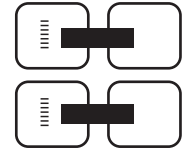

Double-action vacuum systems create a tight fit

The type of seam chosen

FLAT

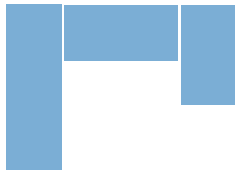

Efficient, most popular with ultra-compact surfaces. With this material, we recommend a tile edge to minimize chips at installation.

This seam is often the default seam by other fabricators, for any material.

ADAPTED

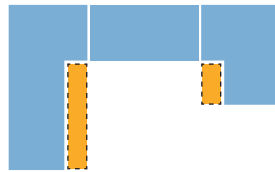

Can improve vein fluidity in a stone. The additional material (in yellow) is billable. Certain factors can impact the feasibility, discuss with our experts.

EUROPEAN



This is the default seam offered by GRANITEDESIGN.

It ensures a tighter fit, better performance, and confuses the eye, making seams less visible.

warranties offered by **GRANITEDESIGN**

Undermount sinks	Seam performance	TREATED natural stone	Mineral & ultra-compact surfaces	<u>untreated</u> Natural Stone
Undermount sink installation adhesion is covered with a 1-yr warranty from date of installation.	Seam performance is covered by a 1-yr warranty from date of installation.	Natural stones are covered with a 15-yr warranty against food & beverage stains. (granite & quartzite only)	Refer yourself to documents available on fabricator websites (ex.: Cosentino)	No warranty against stains.
<p>NO MATERIAL is covered by warranties against cracks, fissures, scratches, discoloration, chips or any other damage that may be in relation to regular use, structural shift, prolonged exposure to elements, misuse, abuse, etc.</p> <p>You have questions, or wish to place a service call? 1-866-761-8700</p>				





which material is best?

The short answer; there are no «better» material. It's all a matter of personal preference and the tolerance thresholds to different particularities that will help determine the best material for a customer's lifestyle.

							Characteristics often encountered	Goes outside?
Ultra-compact (Dekton)								
Solid colored granite (variation 1, dense minerals, less resin)								
Exotic granite (variation 2, 3 & 4, mixed minerals, resined)								
Soapstone								
Quartzite								
Marble								
Mineral Surface							 (dark colors)	

SYMBOL LEGEND

RESISTANCE

Materials are always resistant to, but are never BULLET-PROOF to elements. Forget the indestructible concept.

- Stains
- Scratches
- Heat
- Temperature change
- Acid
- UV Rays

CHARACTERISTICS

Stones are subject to certain phenomenons, that are not defects, but are part of what makes a stone unique.

- Microfissures
- Etching
- Pitting
- Variance in level of shine
- Requires more frequent cleaning
- Possible break of pattern at seam & junctions



Discover a few tricks to maintain your countertops!



frequently asked QUESTIONS

Who is GRANITEDESIGN?

Founded in 1998, we are the largest stone fabricator in North America.

Can appointment times be given?

We provide a tentative window at time of confirmation. However, this timeframe can vary depending on how previous appointments go, road conditions, and other factors beyond our control.

Will technicians dirty my floors?

Our technicians must keep their safety boots, which may track in snow, water, mud, etc. We recommend to protect the floor in a safe manner prior to our arrival, and avoid doing your floor cleaning until after we leave.

What are natural stone advantages?

Their unique beauty is by far the most popular reason. But heat and UV ray resistances are not to be overlooked!

What are mineral surface advantages?

The fairly consistent in pattern and color between slab is the most popular advantage.

What are ultra-compact advantages?

The high resistance to stain, heat and UV rays are the most common ones.

I can feel my seam, is that normal?

Yes. Our technicians take pride in their seam work, but it is rock that is cut and glued back together. It will show. See page 52 for more on this subject.

My countertop is cracked or has a chip. Can it be repaired?

Yes in most cases. Contact our team to know more on how to evaluate costs and schedule a repair.

What will impact a stone's price?

For natural stones, it is often the amount quarried vs. the amount that can be transformed into slabs. The rarity is another factor. For engineered stones (mineral & ultra-compact surfaces) quality of ingredients and the level of R&D invested into the fabrication process from one maker to another will impact price. Then, within the same maker, color popularity will drive price vs. demand.

Does my countertop have radon?

Radon is natural and found everywhere. In a countertop, it is less than 1 millionth, so virtually non-existent. These results were obtained by studies conducted by the Marble Institute of America.

What is thermal shock?

When a hot object/liquid comes into contact with a cold surface. The heat will expand the minerals and resins, which will create stress in the stone. Areas more prone to this are above the dishwasher vent, in an area where slow cookers are often placed, etc. To minimize this, think of using trivets and avoid impacts in these areas.

My stone seems to have rust or oxidation. Is that normal?

With natural stone, it is possible that a repeated exposure to hard water can create this. With mineral & ultra-compact surfaces, the area that often displays this is near the sink (where our buckles will rub against the edge). There are some easy tricks to try and correct the situation using common household products. See page 68 for a QR code that will bring you to care & maintenance tips, or check out page 70!

What are my warranties?

GRANITEDESIGN offers a 1-yr warranty on seam and undermount sink performance. NO WARRANTIES will cover chips, discoloration, cracks, fissures, etc. Material fabricators (ex.: Cosentino) have their own warranty documents on their websites.



the process WHO DOES WHAT

DESIGNER

YOUR ROLE IS TO QUALIFY the customer, to create the concept, to propose the right stone, the right options the project's unique design elements.



MATERIALS

Show the selection

Explain the characteristics to consider.

See page 7 for an overview.



INCLUSIONS

What is included in that price

Refer to the quote/program details.

The price at this stage is **BUDGETARY** and subject to change after final plans are established at template.



ITEMS to have on site for template

Main Decider
Accessories
Cabinets (fixed, level and coplanar, except for PerfectF.I.T.™)

See page 72!



SENDING THE ORDER



PROJECT DETAILS

Include the material, the color, the edge, the approximate sq.ft., the sink type, and any other pertinent information.



IMPORTANT

We do not always have complete information at the time of opening a project. We do a full recap of information with the decision maker. It is important that this person has all key information related to their project.



GOOD PRACTICE

Decision makers expect that we have the information when we contact them. **Send us an email with all the info !**



AS FABRICATORS, our role is to plan, measure, fabricate and install stone surfaces in the most efficient way possible, while ensuring customer satisfaction.



OPENING the project

Complete review of information as received & overview of next step to prepare the decision maker.



TEMPLATE

The technician validates the final plans and so that pricing can be validated.



POST-TEMPLATE

Our Project Agent will confirm final plans, prices, and upon everything approved; will release the job into production.



FABRICATION & INSTALLATION

See page 72!



THE CUSTOMER plays an important role in the success of their project.



UNDERSTANDING what was purchased



LISTENING and following instructions that are provided



BEING READY and available for our technicians. This implies setting aside **an entire day** per appointment. This investment is important, and merits all the time and care that is given to it.

See page 72 for required preparation.

The #1 enemy of your stone surface

[ACCORDING TO OUR STONE ARTISAN YVAN DOYON!]

SPONGES

Think about it, why do we use a sponge... to absorb! Do you really want to clean your countertops, the surface you use to cook on, to place foods on, etc. with the same tool that will absorb everything that you through at it when you clean that greasy pan or your fridge?

Even if you rinse it out with hot soapy water and wring it, a sponge will never be clean after its first use... we put you to the challenge; take a "clean" sponge (meaning a sponge that you have used to wash your dishes that you have rinsed and wrung), and clean any window of your choice..!

The same result that you will get from this little exercise is what you will create on your countertops; but the build-up will be less visible than on glass...

As weeks will go by, that filmy residue will build up and create oily residues on your countertops [you might see cloudlike spots or darker areas]. When our technicians do a service call for a deep clean, the culprit is 99% of the time a sponge.

SO WHAT TO DO?

Say goodbye sponges, and hello clean soft microfibre cloths, that you dedicate to your countertop's cleaning, and that you wash regularly!



Discover a few simple tricks

that are adapted to your type of stone, helping you maintain your stone's beauty!

Share this article with customers!



Preparing customers

THE DECISION MAKER
(18 yrs old or up) MUST
be on-site to approve
our technician's work.



MEASURE



INSTALLATION

- ✓ **THE SITE** is safe, easy to access;
 - ✓ **THE SURFACE** is free of ALL objects;
 - ✓ **THE BACKSPLASH** has the bottom row removed, unless it is kept after install;
 - ✓ **CABINETS** & end panels are installed, fixed to the wall, level and coplanar;
 - ✓ **ACCESSORIES** are on-site (sink, soap dispenser, food grinder, stove/cooktop, etc.) ;
 - ✓ **THE APRON SINK** is in the cabinet, but not permanently fixed.
-
- ✓ **THE SITE** is safe, easy to access, free of debris, ice, snow, etc. ;
 - ✓ **EXISTING COUNTERTOPS** are removed (unless the removal & haul away service is purchased) ;
 - ✓ **FLOORS** and other sensitive objects are protected;
 - ✓ **SERVICES** are disconnected (plumbing, electricity, gas) ;
 - ✓ **THE CABINET** below the sink is emptied (for undermount sink installations) ;
 - ✓ **THE STOVE** is removed from its spot;
 - ✓ **ACCESSORIES** are on-site (sink, faucets, etc.)

we install
STONE.

Check out our technicians in
action!



MEASURE



INSTALLATION



Our technicians take care of the surrounding space and leaves it in a broom clean condition. The material is heavy, **any accidental damage** related to stone handling is **not** covered by **GRANITEDESIGN**. This includes but is not limited to walls, hallways, floors, doors, appliances, etc. Finally, our technicians do not :

- ✗ **RECONNECT plumbing and other services**
Particularly undermount sinks; as the adhesive needs to cure **24 hours** before plumbing can be reconnected. The customer must also coordinate any other reconnecting (gas, electricity, etc.) and install faucets, food grinder supports, dishwasher supports, etc.
- ✗ **IN DEPTH CLEANING**
Our technicians will pick up after themselves and will broom the space, but the installation site is considered an active construction zone; residual dust/snow/mud/water originating from safety boots and/or on-site work/adjustment is to be expected.
- ✗ **SILICONE FINISHING**
The technician will not do a silicone bead on a drop-in sink. Between the countertop and the wall, any application of silicone is to the discretion of the technician; who can apply a first coat if no backsplash is intended, but it will dry and may require a 2nd coat, which will need to be applied by the customer. The silicone finishing is not a seam and is not covered by the 1-year warranty offered by **GRANITEDESIGN**.





Little quiz

to break the ice!

Discover which type of stone best suits your customer's lifestyle!



oops moments

Cleaning is necessary, but I often procrastinate and do cleaning last..!

I LOVE when everything shines! Cleaning makes me zen!



What about your tolerance to imperfection?



What about members of your household...?

My eagle eye sees EVERYTHING

I don't sweat the small stuff, but twice a year, I scrub the entire house from top to bottom!

I am zen, and prefer the more natural/rough look.

UMM... does it count if my furry friend jumps up on countertops?

We are models of perfection, just like me!

The **Dekton** and **mineral surface** will be great for you!

Mineral surfaces, granite and quartzite will suit your lifestyle.

All materials are open to you, but will be able to enjoy **Soapstone** to its fullest.

Marble is a possibility for you! We still recommend a honed finish to respect that stone's unique nature. It will be softer, and etching less visible (see page 7).

Discover the Perfect **F.I.T.**
by GRANITEDESIGNUSA

COUNTERTOP INSTALLATION
1 BUSINESS DAY
after cabinets are fully installed

Consult page 3 for more details!

